

CONFIGURATION	ASSEMBLY PN, ref	SHEET (S)
2 POSITION	TMB-SEH22-XX	SEE SHEET 1,2
4 POSITION	TMB-SEH24-XX	SEE SHEET 1,2
6 POSITION	TMB-SEH26-XX	SEE SHEET 1,2
8 POSITION	TMB-SEH28-XX	SEE SHEET 1,3
10 POSITION	TMB-SEH210-XX	SEE SHEET 1,3

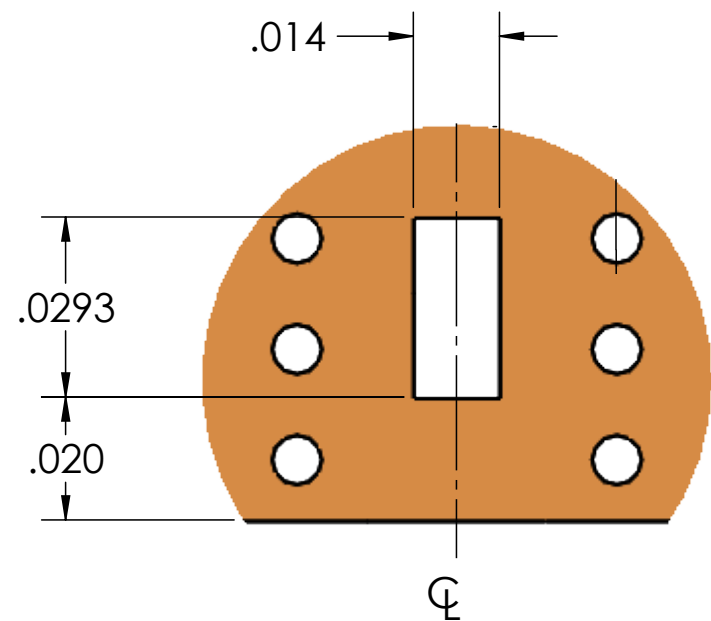

DETAIL D  
LAYER 2 - Cu  
SCALE 32 : 1

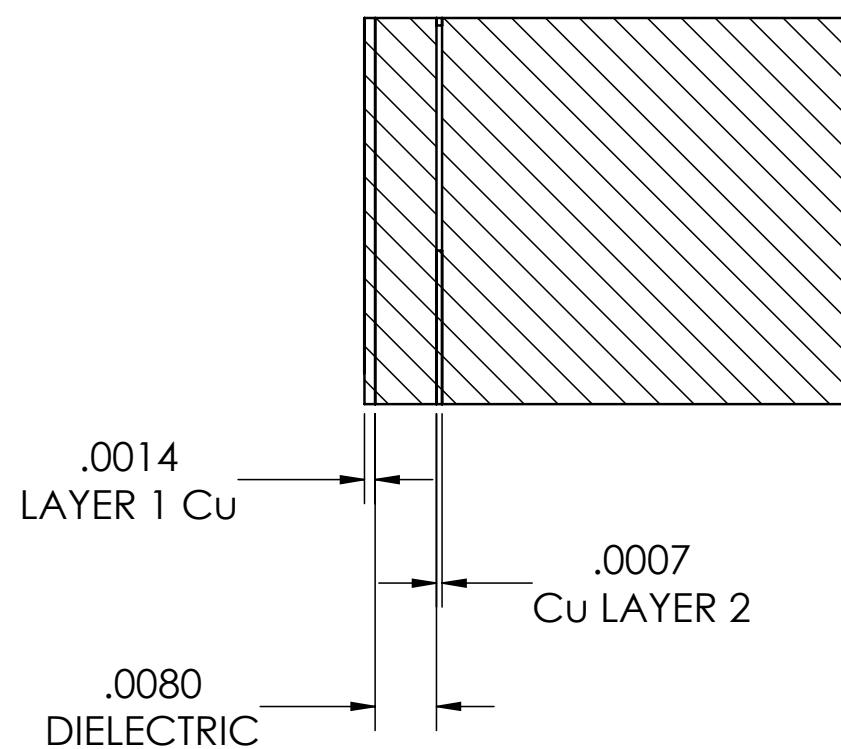

SECTION B-B  
SCALE 40 : 1

REVISIONS			
REV.	DESCRIPTION	DATE	BY
P1	PRELIMINARY RELEASE	03.29.20	HT
01	ADD AREA TO BE ETCH TO PREVENT SOLDER FLOW INTO CONNECTOR THREADED HOLE; ADD NOTE "SOLDEMASK FREE AREA"	08.15.20	HT
02	REMOVE "AREA TO BE ETCHED & FREE OF SOLDER MASK"	08.16.20	HT
03	REVISE DETAIL "D" (ONLY SHOW THE CUTOUT ON LAYER 2)	11.27.23	HT

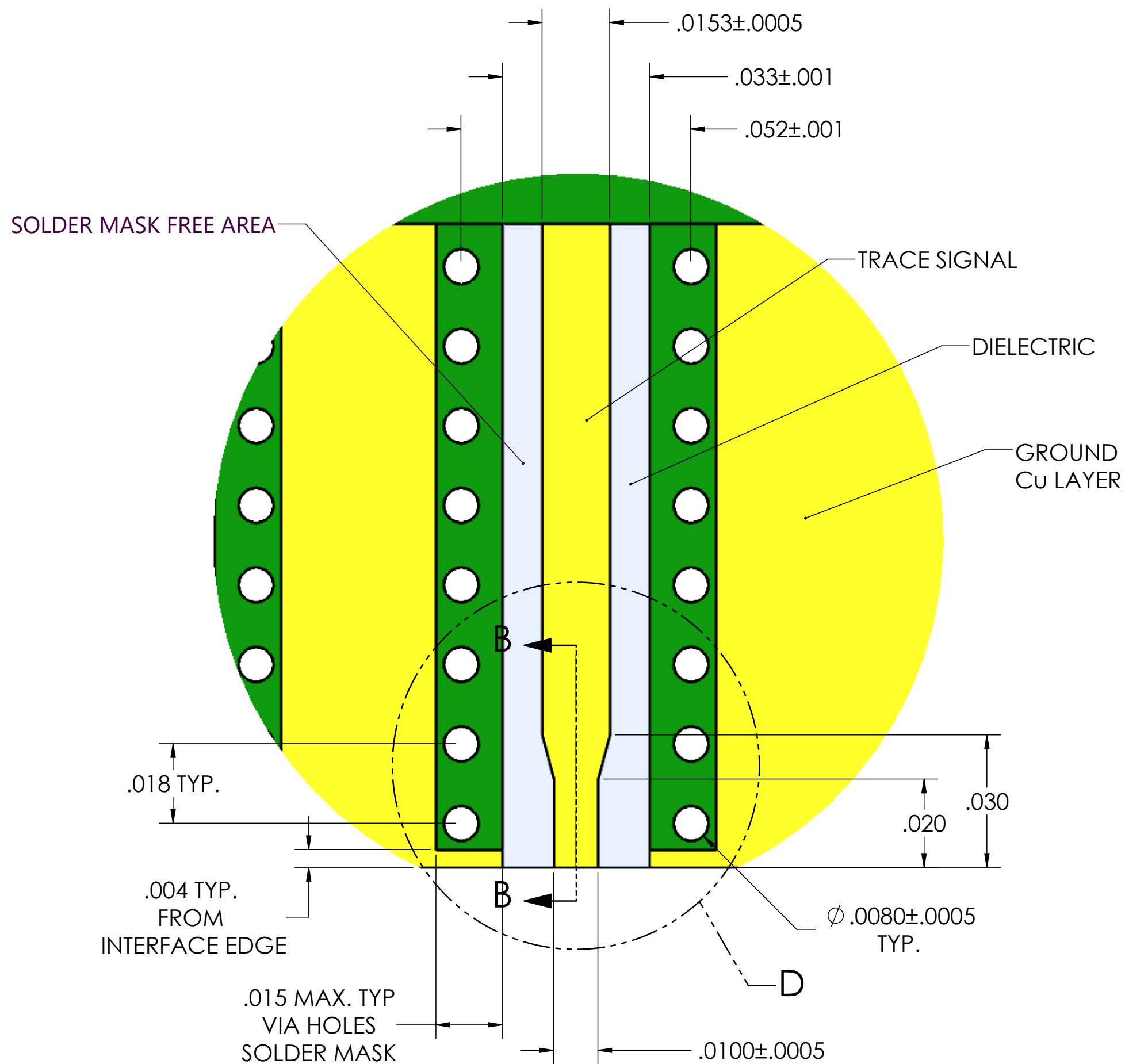

LAYER1 - Cu  
SCALE 40 : 1

APPLICABLE CARLISLE IT DOCUMENTS

WORK STANDARD	PROD INSTRUC	ASSY INSTRUC
NA	NA	NA
-	-	-

**NOTICE**  
THIS DRAWING EMBODIES A CONFIDENTIAL PROPRIETARY DESIGN ORIGINATED BY CARLISLE INTERCONNECT TECHNOLOGIES & ALL DESIGN, MANUFACTURING, REPRODUCTION, USE & SALE RIGHTS REGARDING THE SAME ARE EXPRESSLY RESERVED. IT IS SUBMITTED UNDER A CONFIDENTIAL RELATIONSHIP FOR A SPECIFIED PURPOSE & THE RECIPIENT AGREES BY ACCEPTING THIS DRAWING NOT SUPPLY OR DISCLOSE ANY INFORMATION REGARDING IT TO ANY UNAUTHORIZED PERSON TO INCORPORATE IN OTHER PROJECTS ANY SPECIAL FEATURES PECULIAR TO THIS DESIGN. ALL PATENT RIGHTS HERETO ARE EXPRESSLY RESERVED BY CARLISLE INTERCONNECT TECHNOLOGIES, CERRITOS, CALIFORNIA 90703.

TOLERANCES AND NOTES  
EXCEPT AS NOTED

- DIMENSIONS ARE IN INCHES.  
XX ± .015  
LINEAR .XXX ± .005 ANGULAR ± 1/2°  
FRACTION ± 1/32
- MACHINE FINISH: 63/RMS
  - BREAK ALL SHARP EDGES .003 MAX.
  - MACHINED FILLETS .005 MAX.
  - MACHINED SURFACES SQUARE TO RESPECTIVE AXIS WITHIN .005 INCHES PER INCH.
  - MACHINED DIAMETERS CONCENTRIC WITHIN .002 T.I.R.
  - DIMENSIONS TO BE MET BEFORE PLATING.
  - CHAMFER ALL THREADS 45°.
  - THREADS PER H-28
  - REMOVE FRAYED EDGES ON TEFLON.
  - REMOVE ALL BURRS.

MATERIAL		SPECIFICATION		PROCUREMENT	
APPROVAL	INITIALS	DATE	-		-
DRAWN BY	HT	03.29.20	-		-
CHECKED BY	-	-	-		-
TEST ENGR	-	-	-		-
QUALITY	-	-	-		-
DESIGN ENG	HT	03.29.20	-		-
MFG. ENGR	-	-	-		-
ECO APPRV	-	-	-		-

TITLE		SCALE		SUB-DIRECTORY/	
HC2(2.5mm)-EDGE LAUNCH, FOOTPRINT		4:1		-	
SIZE	CAGE CODE	DRAWING NO.	SHEET 1 OF 3		REV.
C	30990	TMB-SEH2X-FOOTPRINT			03

4

3

2

1

D

D

C

C

B

B

A

A

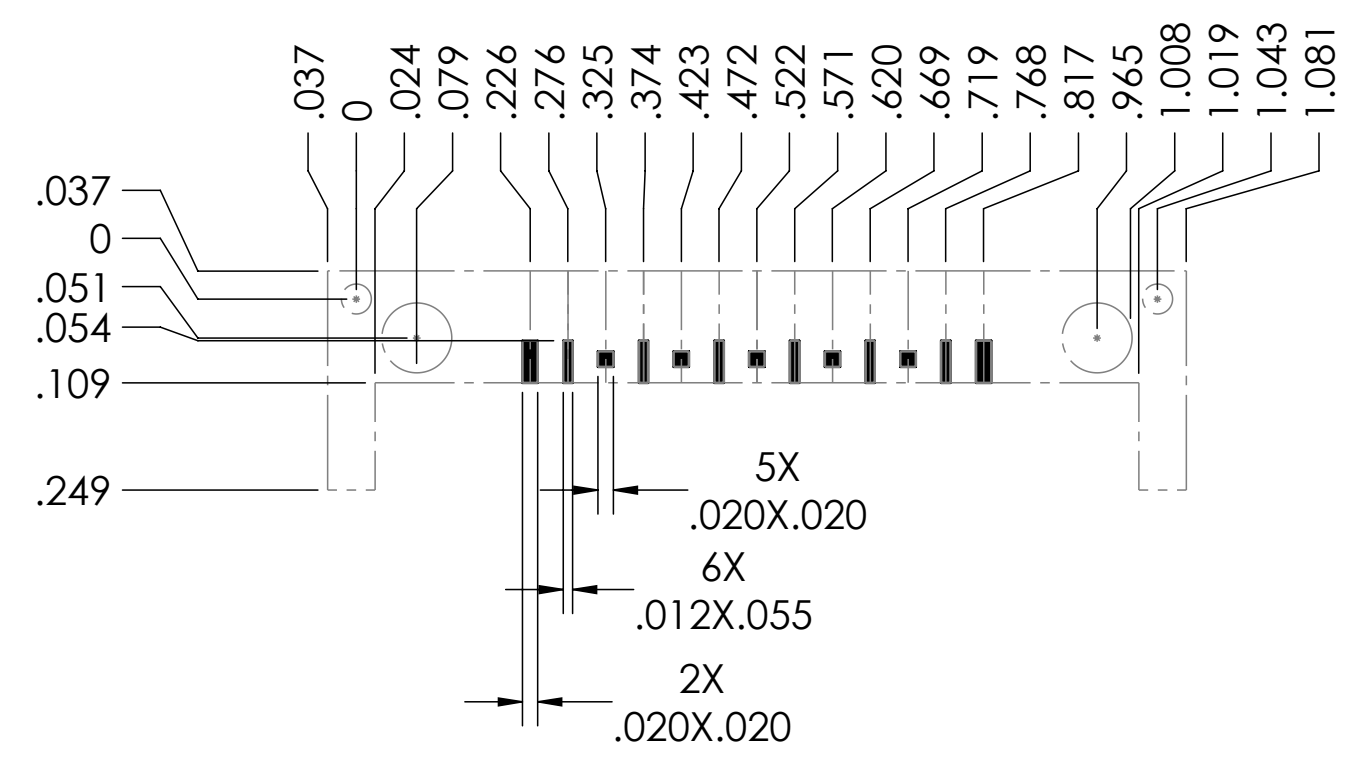
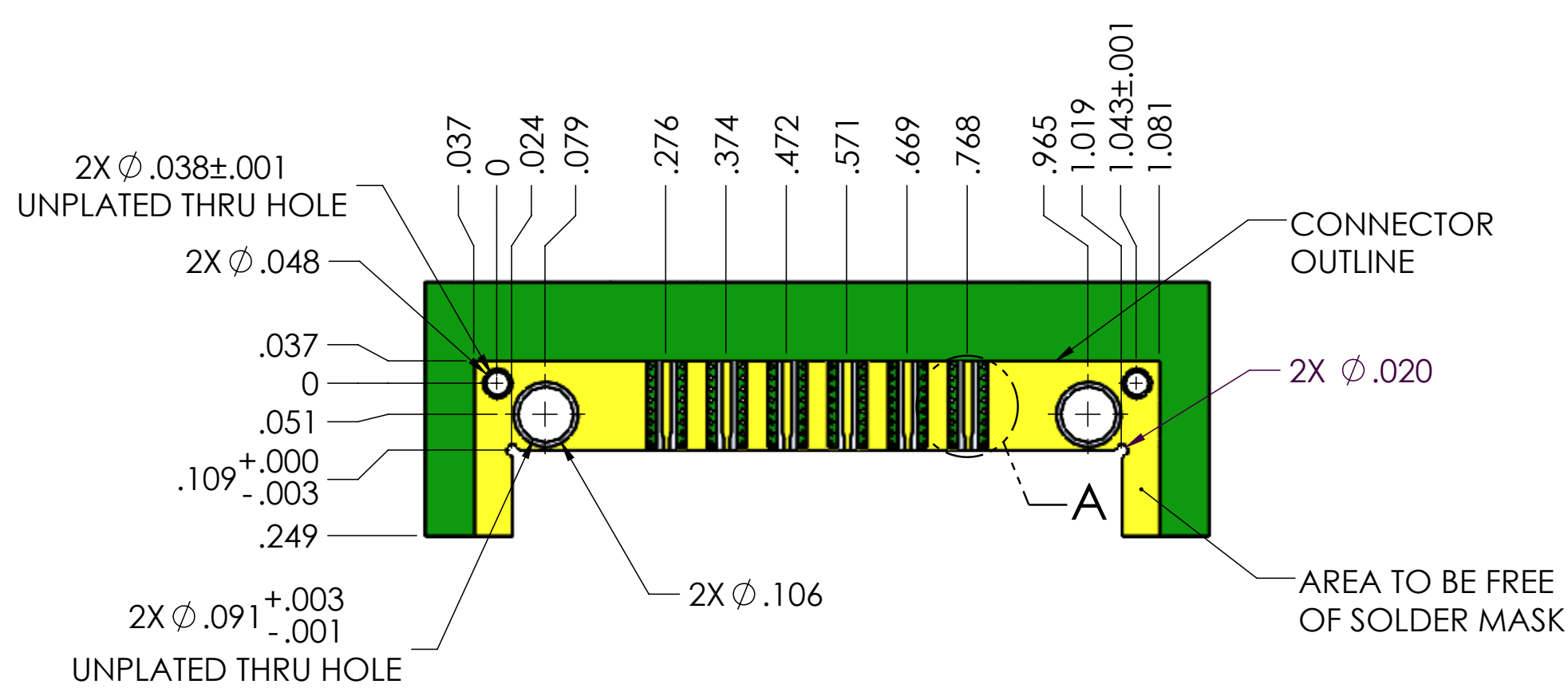
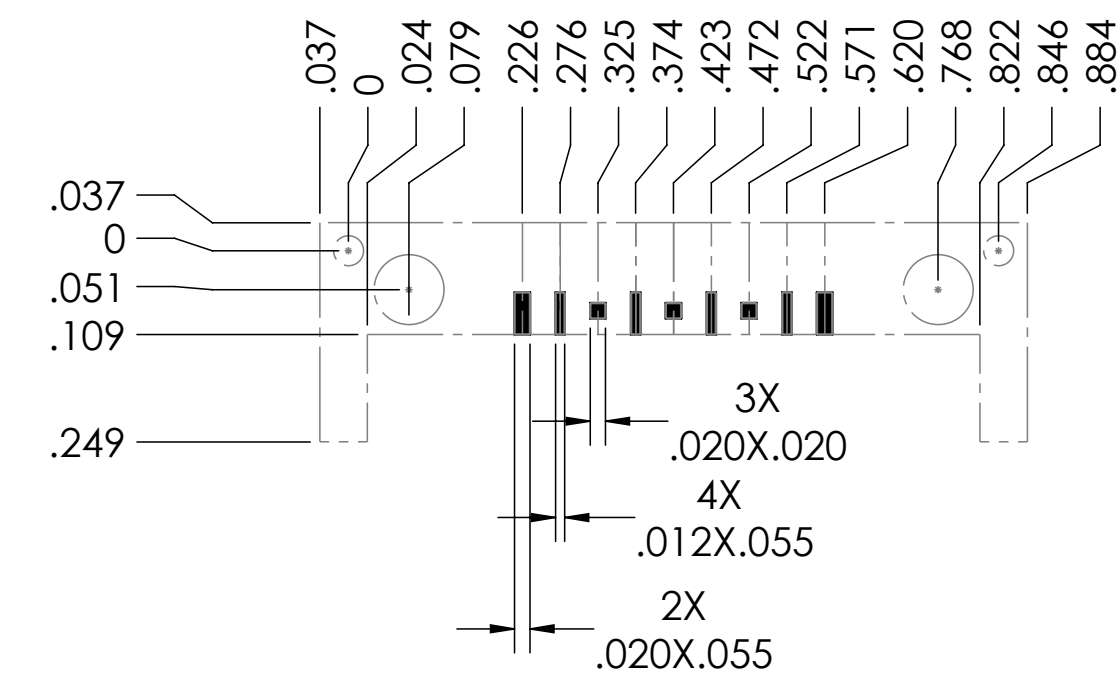
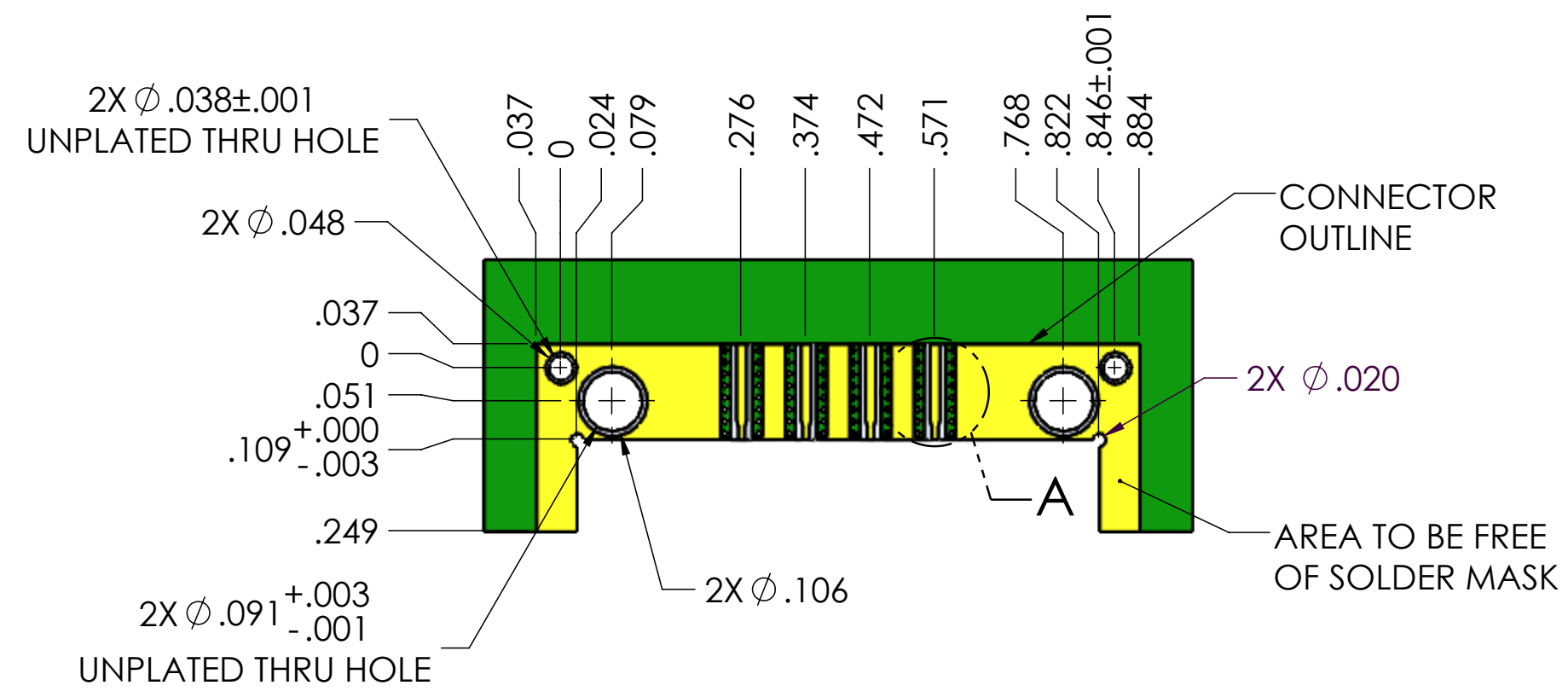
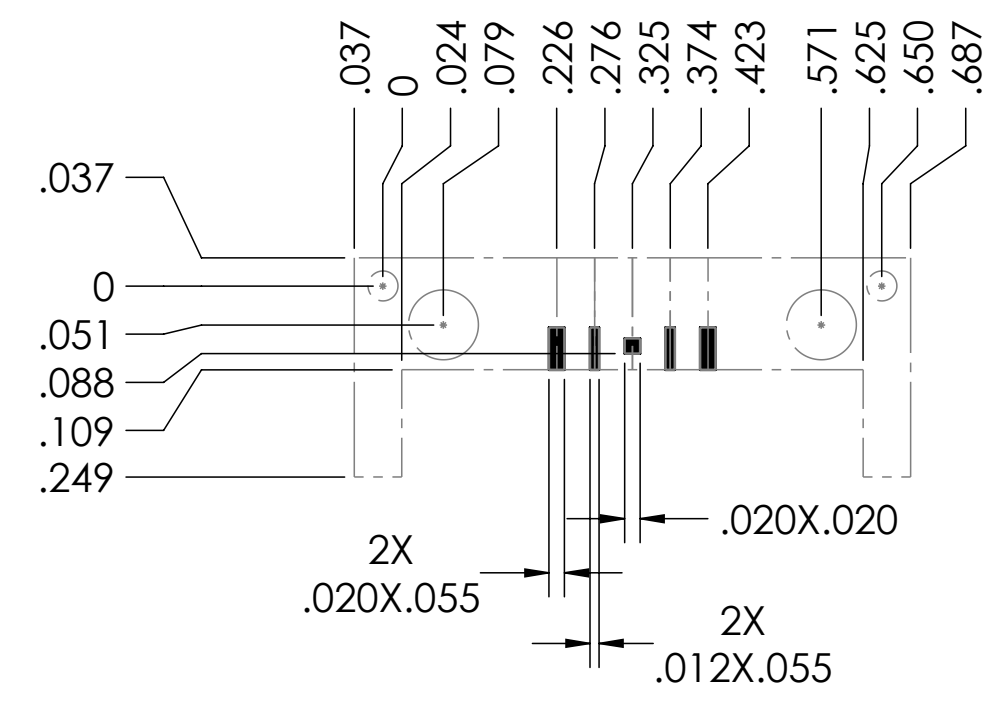
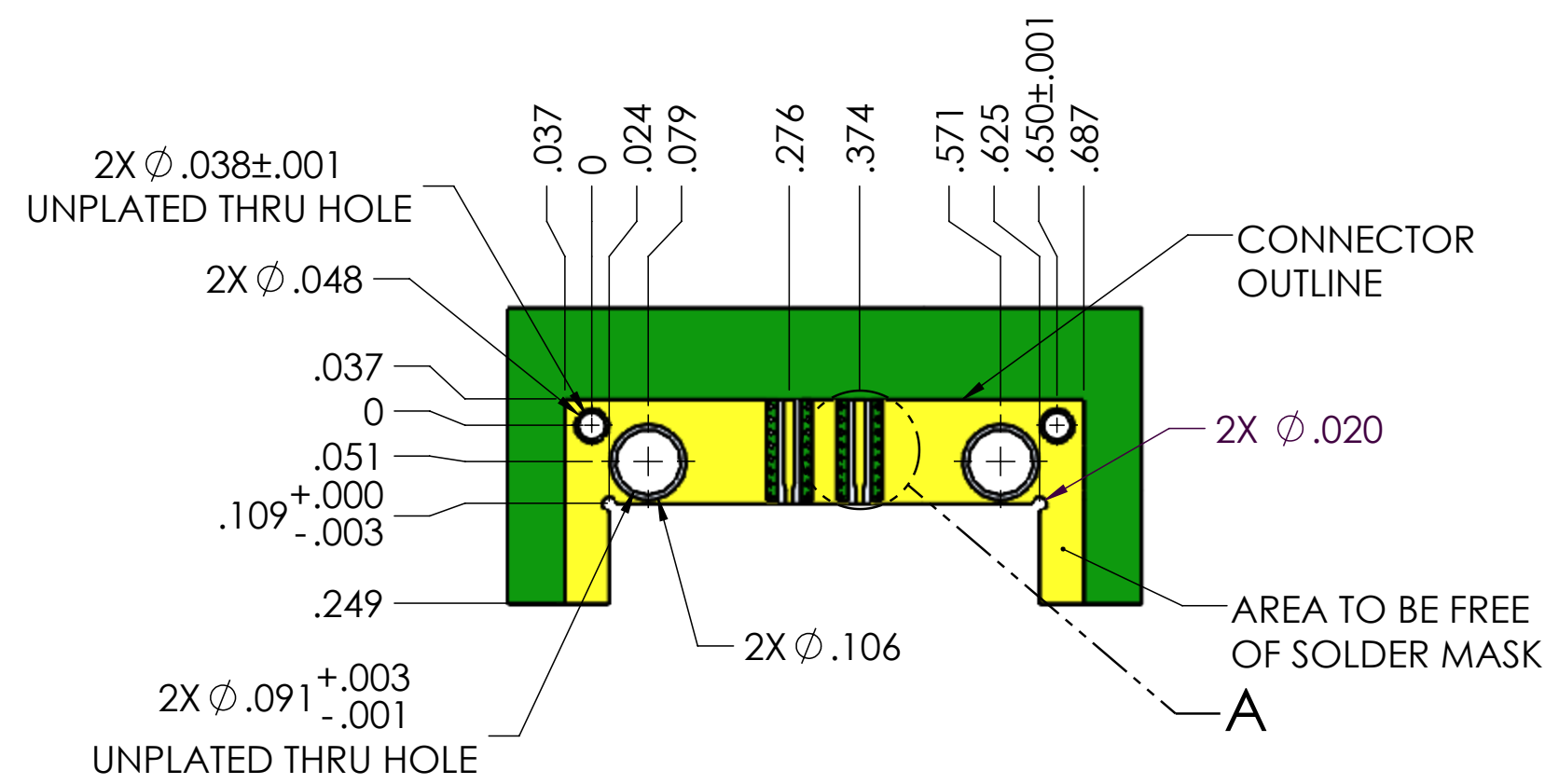

# HC2(2.5mm) EDGE LAUNCH-RECOMMENDED FOOTPRINT

# FOOTPRINT STENCIL

4

3

2

1

SCALE	SUB-DIRECTORY/		SHEET 2 OF 3
4:1			
SIZE	CAGE CODE	DRAWING NO.	REV.
C	30990	TMB-SEH2X-FOOTPRINT	03

4 3 2 1

D

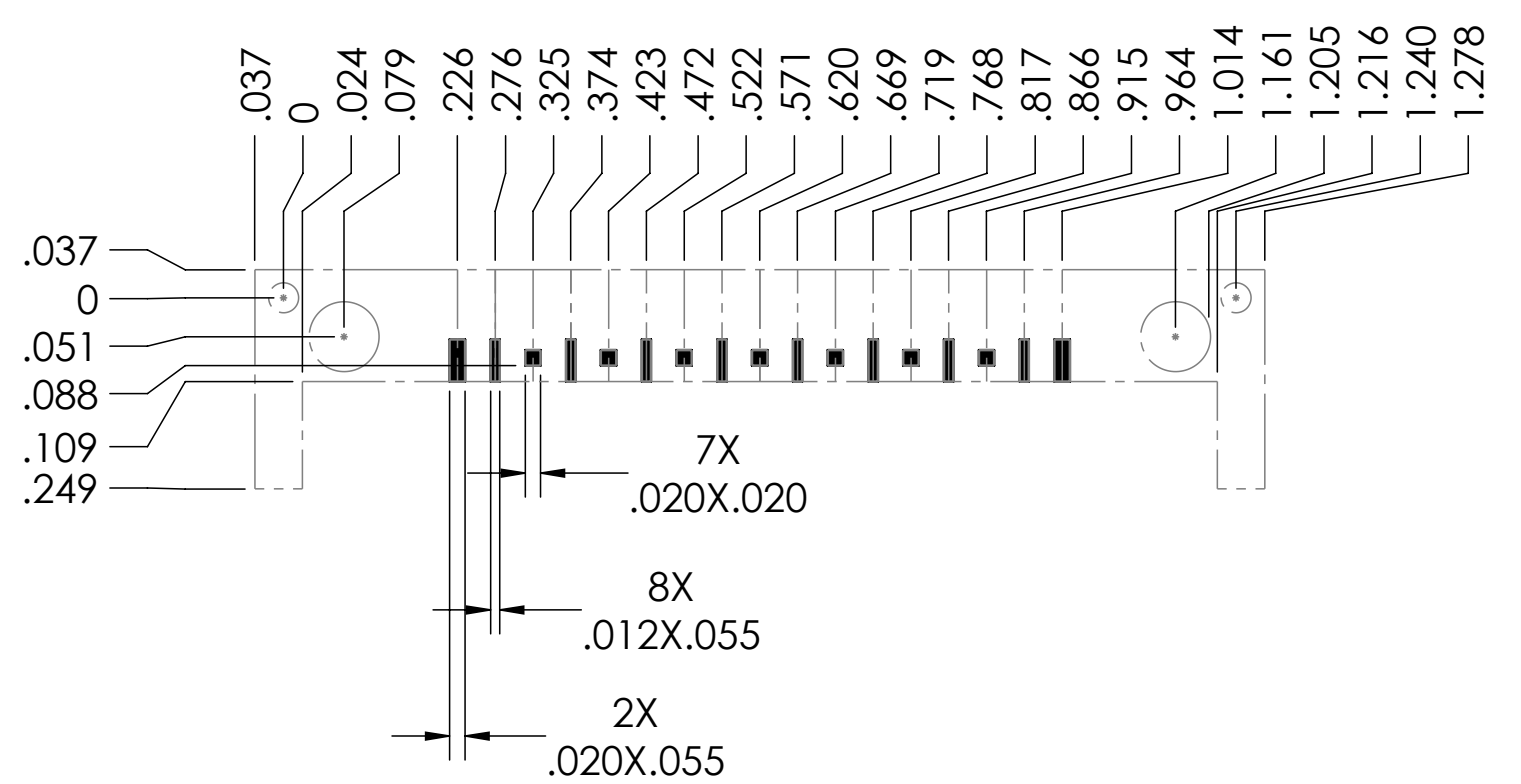
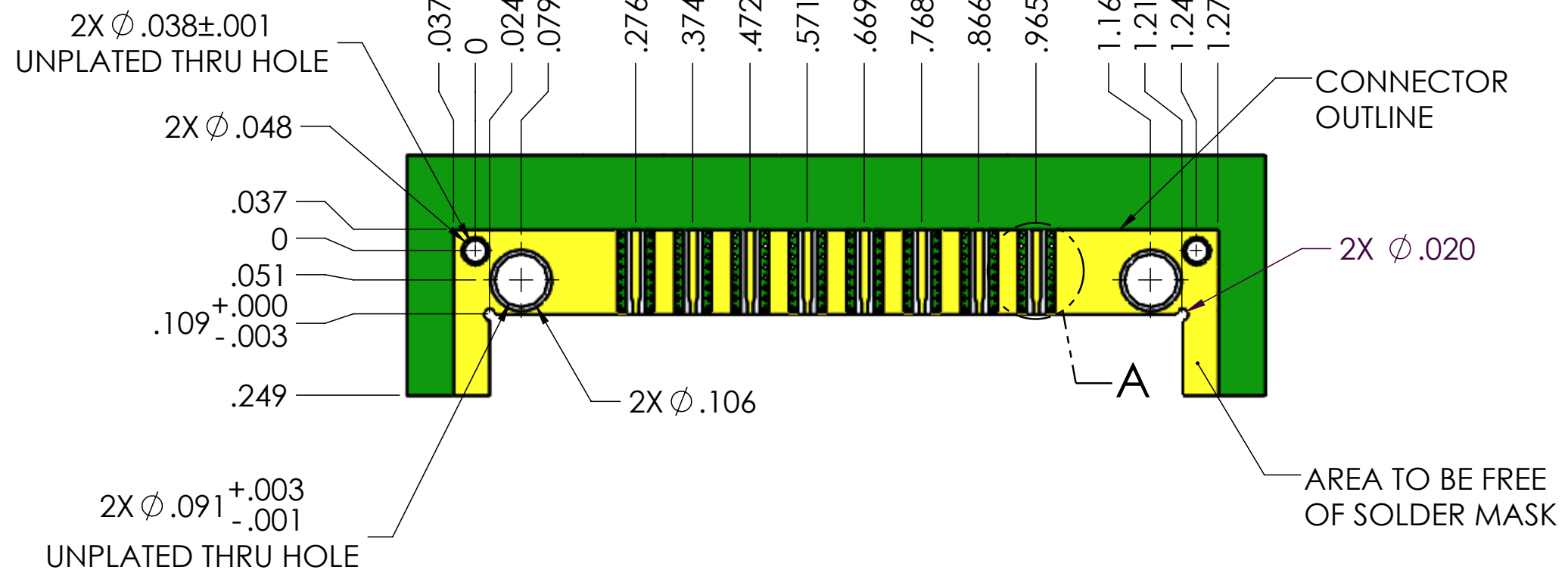

C

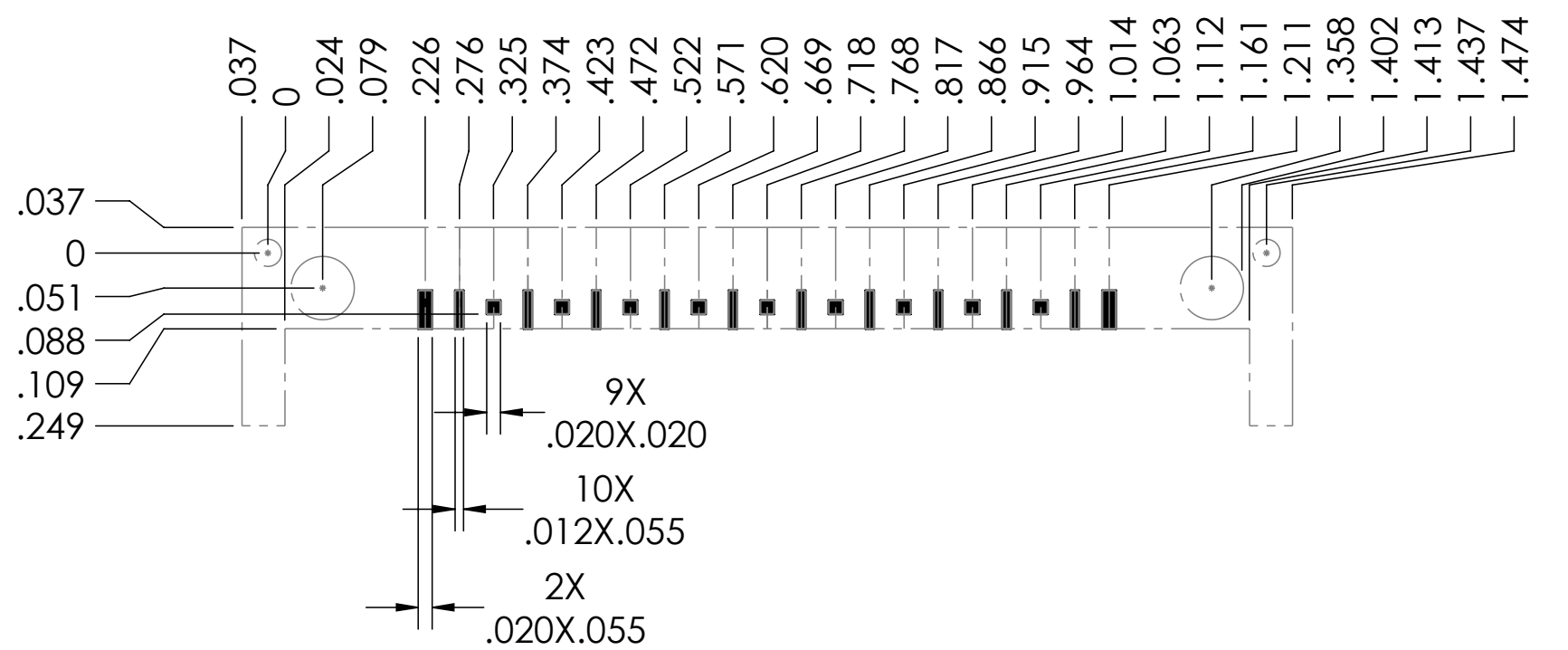
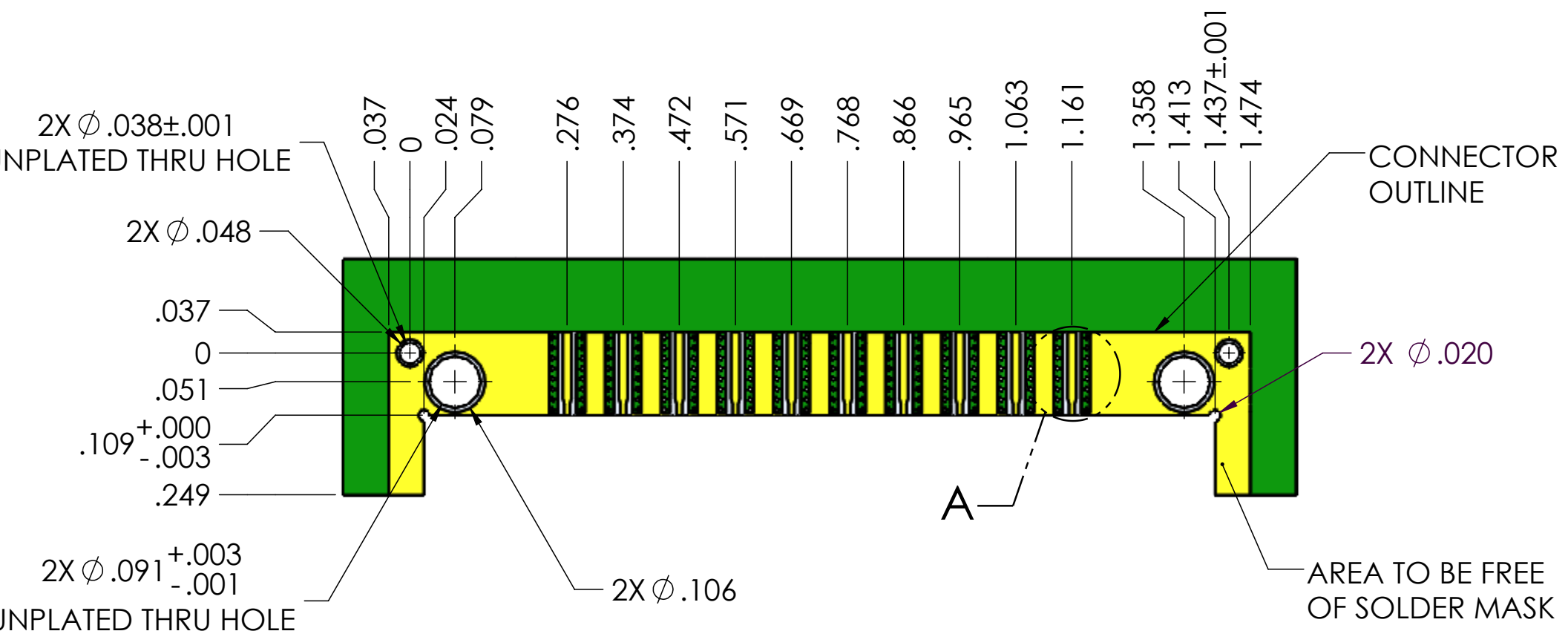

A

**HC2(2.5mm) EDGE LAUNCH-RECOMMENDED FOOTPRINT**

**FOOTPRINT STENCIL**

4 3 2 1

SCALE	SUB-DIRECTORY/		SHEET 3 OF 3
4:1			
SIZE	CAGE CODE	DRAWING NO.	REV.
C	30990	TMB-SEH2X-FOOTPRINT	03