

This print and associated documents and the contained information are the confidential property of ELECTRONIC CABLE SPECIALISTS. Disclosure of, and/or reproduction of, all or part thereof or manufacture of any part from information contained on this print not specifically permitted by ELECTRONIC CABLE SPECIALISTS in writing is forbidden.

REVISIONS					
ECN	ZONE	REV.	DESCRIPTION	DATE	APPROVED
21604	-	N/C	NEW RELEASE	12/20/04	DEK
40648	C3 B4	A	NOTE 4 DEL "OR CRIMP WITH Y1757 DIE" TERM STYLE SPEC, DELETED "CRIMP"	7/16/10	DS/K

**INSTALLATION INSTRUCTIONS**

1. BEGIN BY CUTTING THE CABLE OFF SQUARE.

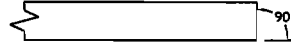

2. WHEN USING AUTOMATIC STRIPPING EQUIPMENT, STRIP CABLE AS SHOWN STARTING WITH L1 AND ENDING WITH L3. TAKE CARE NOT TO NICK THE CONDUCTORS WHILE STRIPPING THE DIELECTRIC AND JACKET. IF AUTOMATIC STRIPPING EQUIPMENT IS NOT AVAILABLE, STRIP ONLY L1 AND L3 AND TRIM EXCESS BRAID AT STEP 10.

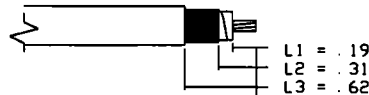

3. SLIDE THE FERRULE AND ADHESIVE SHRINK TUBING OVER THE END OF THE CABLE.  $\Delta$ 1



4. SOLDER THE CONTACT ONTO THE CENTER CONDUCTOR, PER MIL-STD-2000, USING 63Sn/37Pb SOLDER. ENSURE THE CONTACT IS BUTTED AGAINST THE CABLE DIELECTRIC. CLEAN ALL FLUX RESIDUES USING AN APPROPRIATE FLUX CLEANER.



5. USING TWEEZERS, FOLD THE OUTER BRAID BACK OVER THE CABLE JACKET, LEAVING AS MUCH WEAVE AS POSSIBLE.

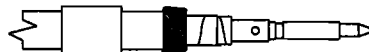

6. SLICE THE ALUMINUM/POLYESTER FOIL LENGTHWISE ABOUT EVERY 1/8". GENTLY ROTATE PIN TO SEPARATE THE FLAT FOIL BRAID AND ALUMINUM/POLYESTER FOIL FROM THE DIELECTRIC. USING TWEEZERS, FOLD BACK ALUMINUM/POLYESTER FOIL OVER THE OUTER BRAID.



7. USING TWEEZERS, FOLD THE INNER BRAID BACK OVER THE OTHER SHIELDS, LEAVING AS MUCH WEAVE AS POSSIBLE. NOTE: DO NOT UNRAVEL DIELECTRIC WHEN PULLING BACK INNER SHIELD.



8. SLIDE THE BODY OF THE CONNECTOR OVER THE END OF THE CABLE UNTIL THE NOTCH IN THE CONTACT SEATS INTO THE DIELECTRIC RIDGE INSIDE THE CONNECTOR BODY.

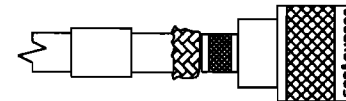

9. FOLD ALL THREE BRAIDS UP OVER THE NECK OF THE CONNECTOR BODY.

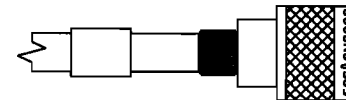

10. SLIDE THE FERRULE UP OVER THE SHIELDS AND UP AGAINST THE CONNECTOR BODY. TRIM AWAY ANY EXCESS BRAID. CRIMP THE FERRULE ONCE, NEXT TO THE BODY, USING THE M22520/5-31 DIE IN A M22520/5-01 TOOL FRAME. APPLY ADHESIVE HEAT SHRINK.  $\Delta$ 2

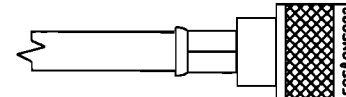

**NOTES**

- $\Delta$ 1 INSURE HEAT SHRINK IS INSTALLED PRIOR TO CRIMPING CONNECTOR.
- $\Delta$ 2 ADHESIVE HEAT SHRINK SHOULD BE APPLIED IN ACCORDANCE WITH ECS WORK INSTRUCTION W1007. CONTACT ECS FOR A COPY OF THIS WORK INSTRUCTION.
- $\Delta$ 3 CONNECTOR DIMENSIONS ARE FOR REFERENCE ONLY.

D

D

C

C

B

B

A

A

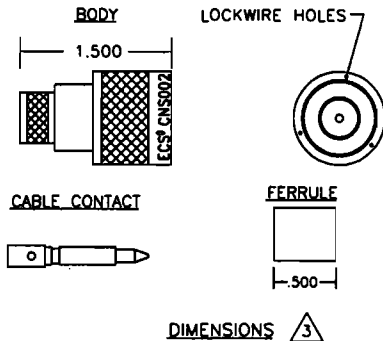

**SPECIFICATIONS**

**ELECTRICAL**  
 IMPEDANCE: 50 OHMS NOMINAL  
 FREQUENCY RANGE: 0-11 GHz  
 VSWR: 1.2:1 MAXIMUM DC TO 2GHz  
 INSERTION LOSS: .1dB MAXIMUM DC TO 2GHz  
 WORKING VOLTAGE: 1000 VRMS @ SEA LEVEL  
 DIELECTRIC WITHSTANDING: 2500 VRMS @ SEA LEVEL  
 INSULATION RESISTANCE: 5000 MEGOHMS MINIMUM  
 @ 500 VOLTS DC

**MECHANICAL**  
 CONNECTOR INTERFACE: DIMENSIONS PER MIL-STD-348A  
 FIGURE 304-1 (N)  
 TERMINATION STYLE: CENTER CONTACT-SOLDER ONLY  
 FERRULE-CRIMP  
 CABLE RETENTION: 60 LBS

**ENVIRONMENTAL**  
 TEMPERATURE RATING: -65° TO +165° C  
 VIBRATION: MIL-STD-202, METHOD 204, COND. B  
 SHOCK: MIL-STD-202, METHOD 213, COND. 1  
 THERMAL SHOCK: MIL-STD-202, METHOD 107, COND. B  
 CORROSION: MIL-STD-202, METHOD 101, COND. B  
 MOISTURE RESISTANCE: MIL-STD-202, METHOD 106

**MATERIALS**  
 BODY: BRASS PER QQ-B-626  
 FERRULE: ANNEALED BRASS PER QQ-B-626  
 CENTER CONTACT: BRASS PER QQ-B-626  
 OUTER CONTACT: BRASS PER QQ-B-626  
 DIELECTRIC: TEFLON PER L-P-403  
 GASKET: SILICONE RUBBER PER ZZ-R-765

**FINISHES**  
 BODY, FERRULE AND OUTER CONTACT: BRIGHT NICKEL  
 PER QQ-N-290  
 CENTER CONTACT: GOLD PER MIL-G-45204

ALL LENGTHS IN INCHES		ELECTRONIC CABLE SPECIALISTS FRANKLIN, WI 53132 PHONE: (414) 421-5300	
APPROVALS	DATE	TITLE: <b>CUSTOMER SPECIFICATION</b>	
DRAWN BY: C CHAPMAN	12/14/04	STRAIGHT N TYPE PLUG FOR ECS CABLE 310701	
CHECKED BY: D KNOLL	12/20/04	SIZE: B	CAGE CODE: 66197
DESIGNED BY:		LEVEL:	PART NO.: CNS002
PROJECT ENG:		SCALE:	FILE NO: F:\E\SPEC\COMM\INST\CNS002
ENG. MGR: D KNOLL	12/20/04	SHEET: 1 OF 1	