

ST02612CH

FAA Supplemental Type Certificate



Installation of AD Aerospace Cockpit Door Monitoring System on Airbus A318, A319, A320, and A321 Series Aircraft (FAA STC ST02612CH)

OVERVIEW

- » FAA STC ST02612CH.
- » European Aviation Safety Agency (EASA) STC 03120.

INTRODUCTION

STC ST02612CH enables approved installation of AD Aerospace Cockpit Door Monitoring System in accordance with Electronic Cable Specialists (ECS) Master Data List ECS-206333.

YOUR NEEDS

Enhance operational safety and security by introducing the ability to monitor cockpit door surroundings.

YOUR BENEFITS

Installation the AD Aerospace Cockpit Door Monitoring System in accordance with STC ST02612CH allows the flight crew the ability to monitor the cabin area immediately aft of the cockpit door without opening the cockpit door. Several countries require cockpit door surveillance for commercial aircraft to operate in international airspace.

STC AIRCRAFT EFFECTIVITY

- » Airbus A318-111/-112/-121/-122 series aircraft
- » Airbus A319-111/-112/-113/-114/-115/-131/-132/-133 series aircraft
- » Airbus A320-111/-211/-212/-214/-231/-232/-233 series aircraft
- » Airbus A321-111/-112/-131/-211/-212/-213/-231/-232.

STC LIMITATIONS

- » None

STC CONFIGURATIONS

- » Configuration 1: CDMS installation, dual monitors, and control panels with three cameras.

Contact CarlisleIT for usage rights, derivative configurations, and installation lead time (800) 327-9473 • sales@carlisleit.com

PRODUCT DESCRIPTION

Configuration 1: XM Weather Receiver and Data Port Installation

- » The CDMS consists of three cameras mounted in the area aft of the flight deck door and a monitor and control panel located on the captain's and first officer's outboard waste bin and headset compartments. One camera is mounted above the cockpit door, one camera is mounted above the right cabin door, and one camera is mounted above the left cabin door. The monitors, control panels, and cameras interface with a video switch unit, which is mounted above the ceiling, near the right cabin door, and just aft of the flight deck door.
- » The video switch unit is connected to the 28 VDC bus (28 VDC is supplied to the monitors and cameras from the video switch unit).
- » The CDMS is protected by the following circuit breakers located on the avionics circuit breaker panel.

Label	Function	Rating	Bus
CDMS	CDMS circuit breaker	2 amp	28 VDC BUS 1

MECHANICAL CHANGES

- » Two cameras are installed in the forward galley ceiling and one camera is installed above the cockpit door.
- » One control panel and one video monitor are mounted on the left side of the captain's seat. The mounting provisions are installed in the area previously occupied by the captain's wastebasket.
- » One control panel and one video monitor are mounted on the right side of the first officer's seat. The mounting provisions are installed in the area previously occupied by the first officer's wastebasket.

ST02612CH

FAA Supplemental Type Certificate

- » A video switching unit is installed above the forward galley ceiling.
- » Refer to the following Figures for additional details..

ELECTRICAL CHANGES

The following electrical changes are made for Configuration 1:

- » Power, ground, and data wiring is installed between the three camera connectors and an associated video switch connector.
- » Power, ground, and data wiring is installed between each monitor connector, control panel connector, and a video switch

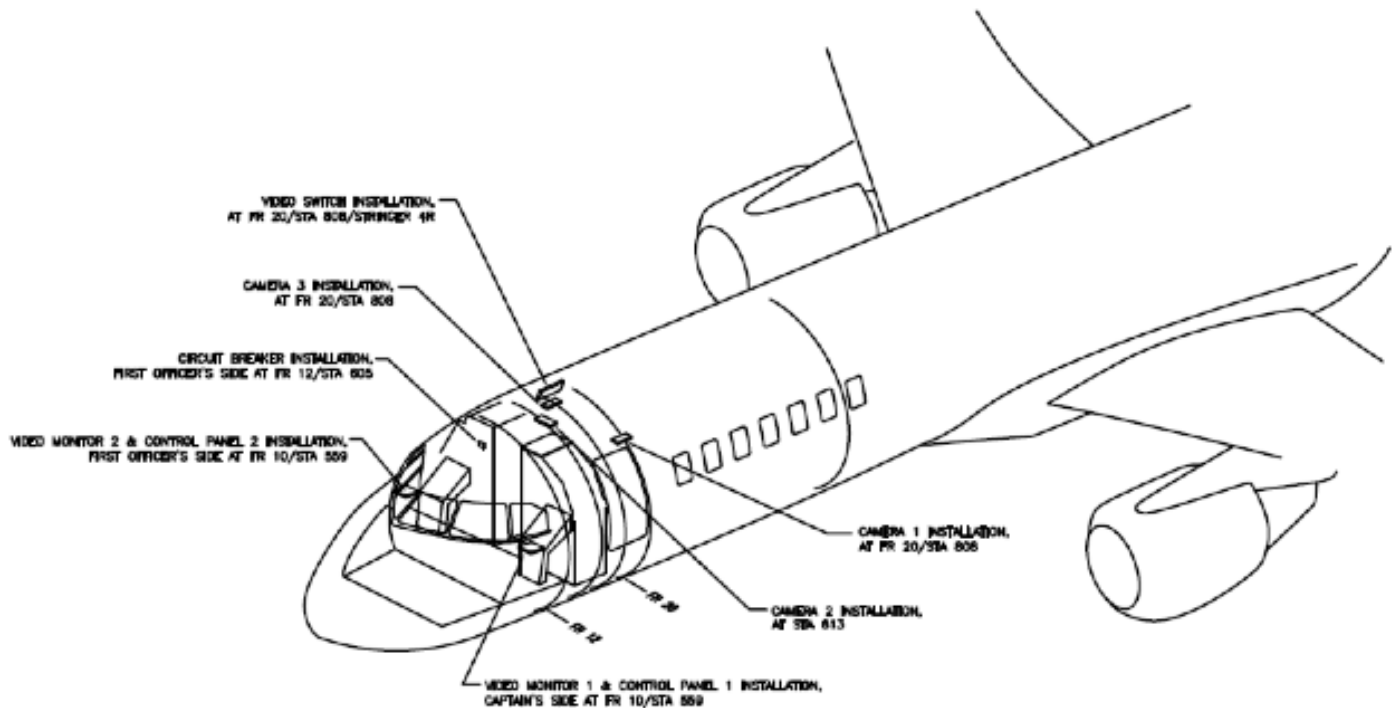

FIGURE 1 - INSTALLATION OVERVIEW

ST02612CH

FAA Supplemental Type Certificate

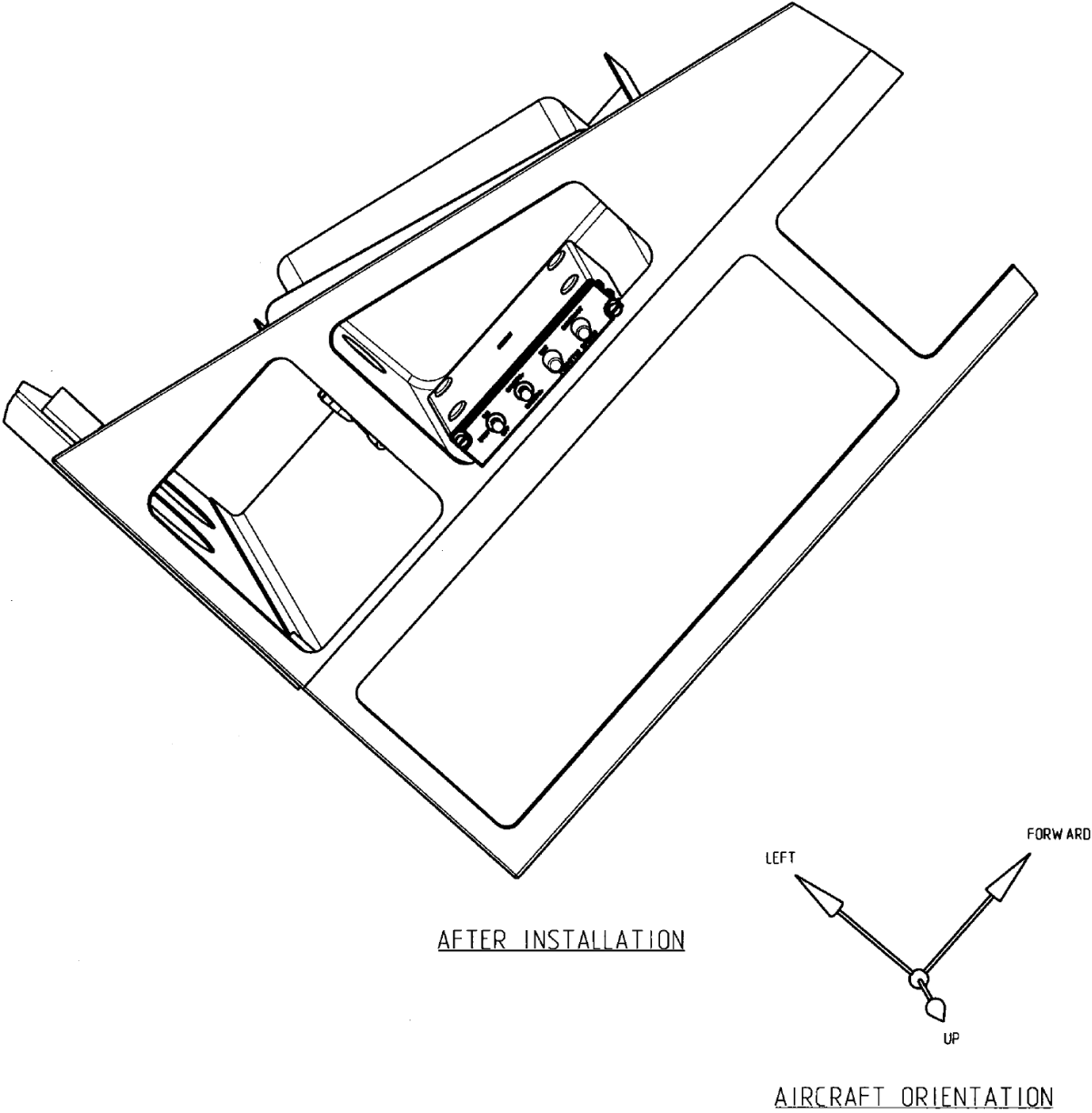
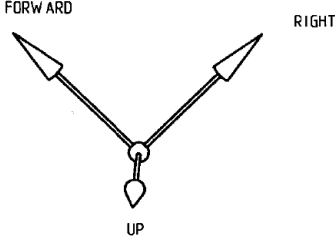
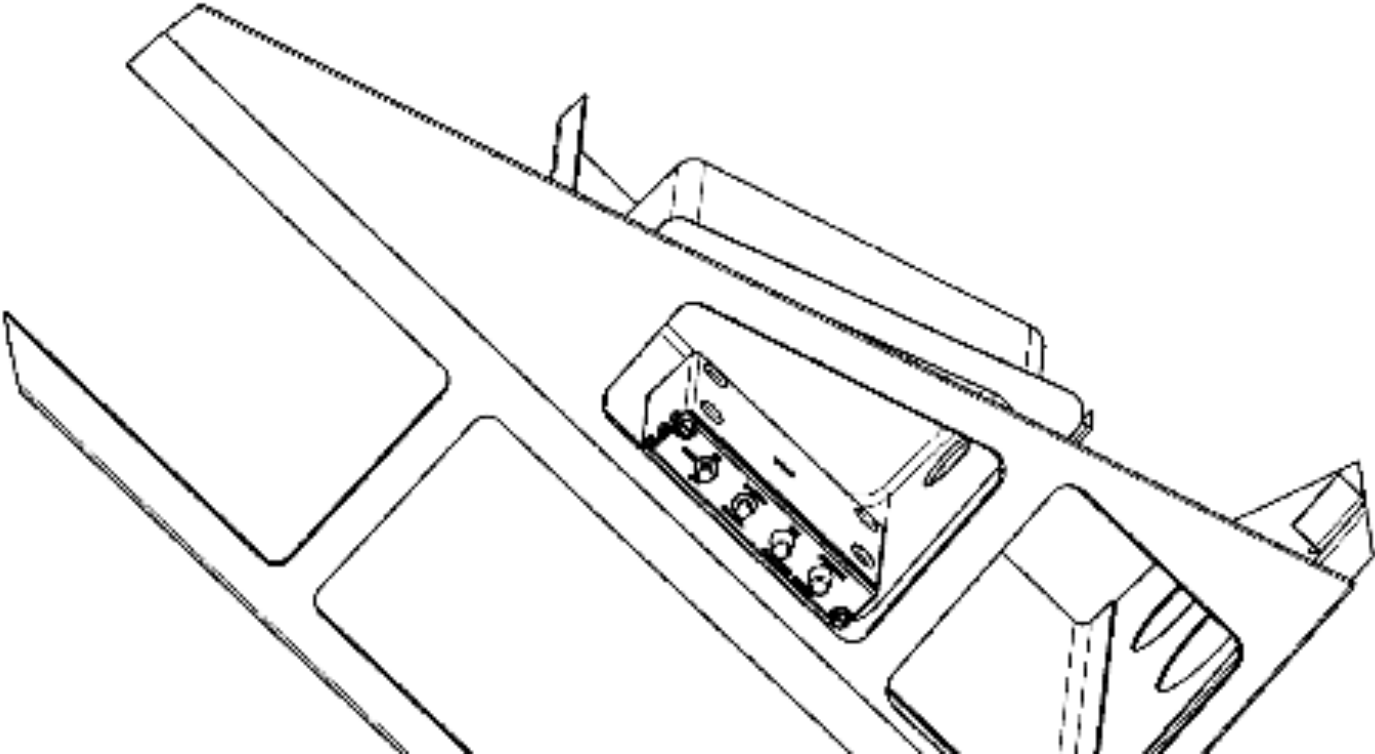

FIGURE 2 - CDMS CONTROL PANEL INSTALLATION, PILOT

ST02612CH

FAA Supplemental Type Certificate



AIRCRAFT ORIENTATION

FIGURE 3 - CDMS CONTROL PANEL INSTALLATION, FIRST OFFICER

ST02612CH

FAA Supplemental Type Certificate

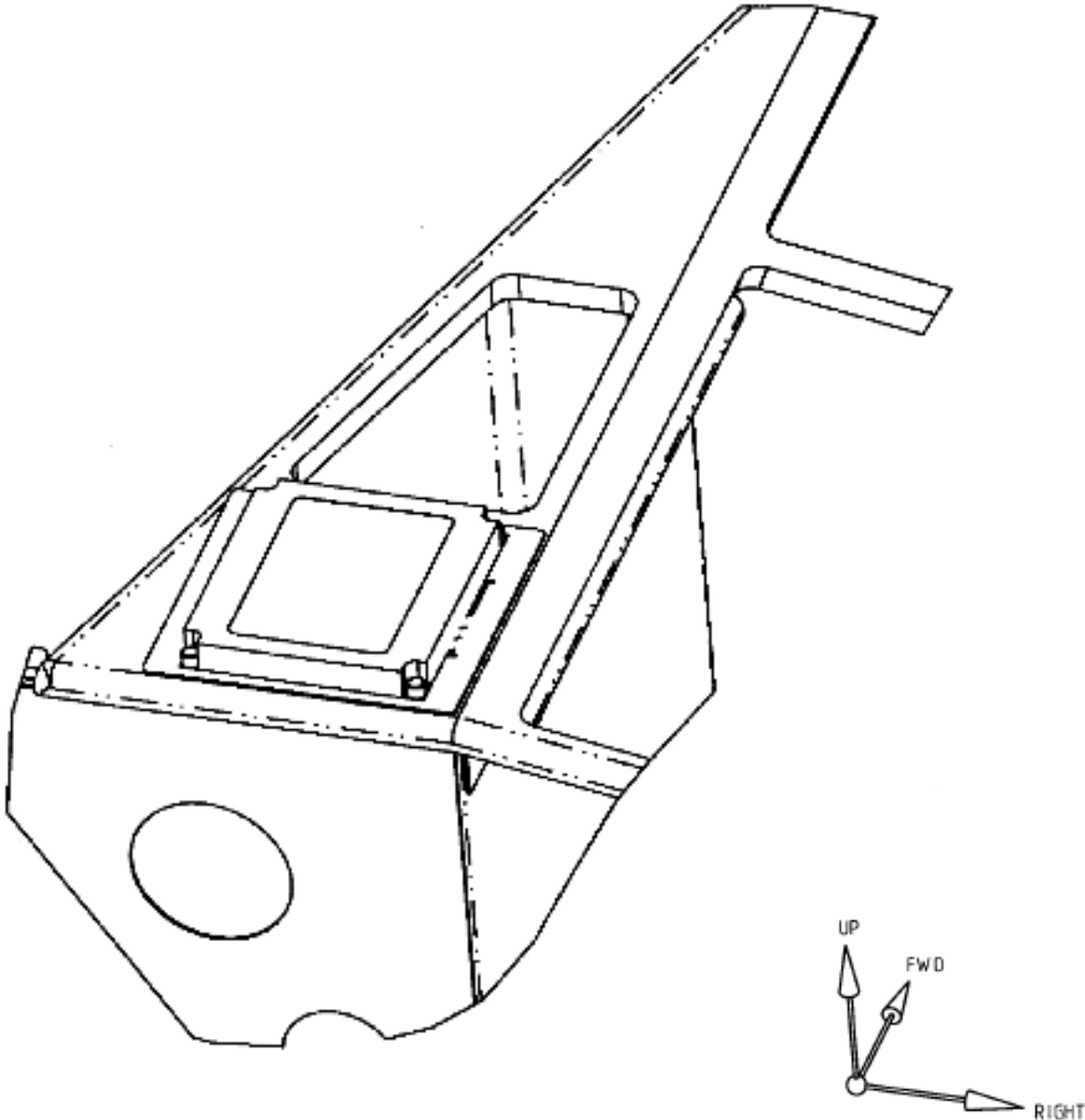

FIGURE 4 - CDMS MONITOR INSTALLATION, PILOT

ST02612CH

FAA Supplemental Type Certificate

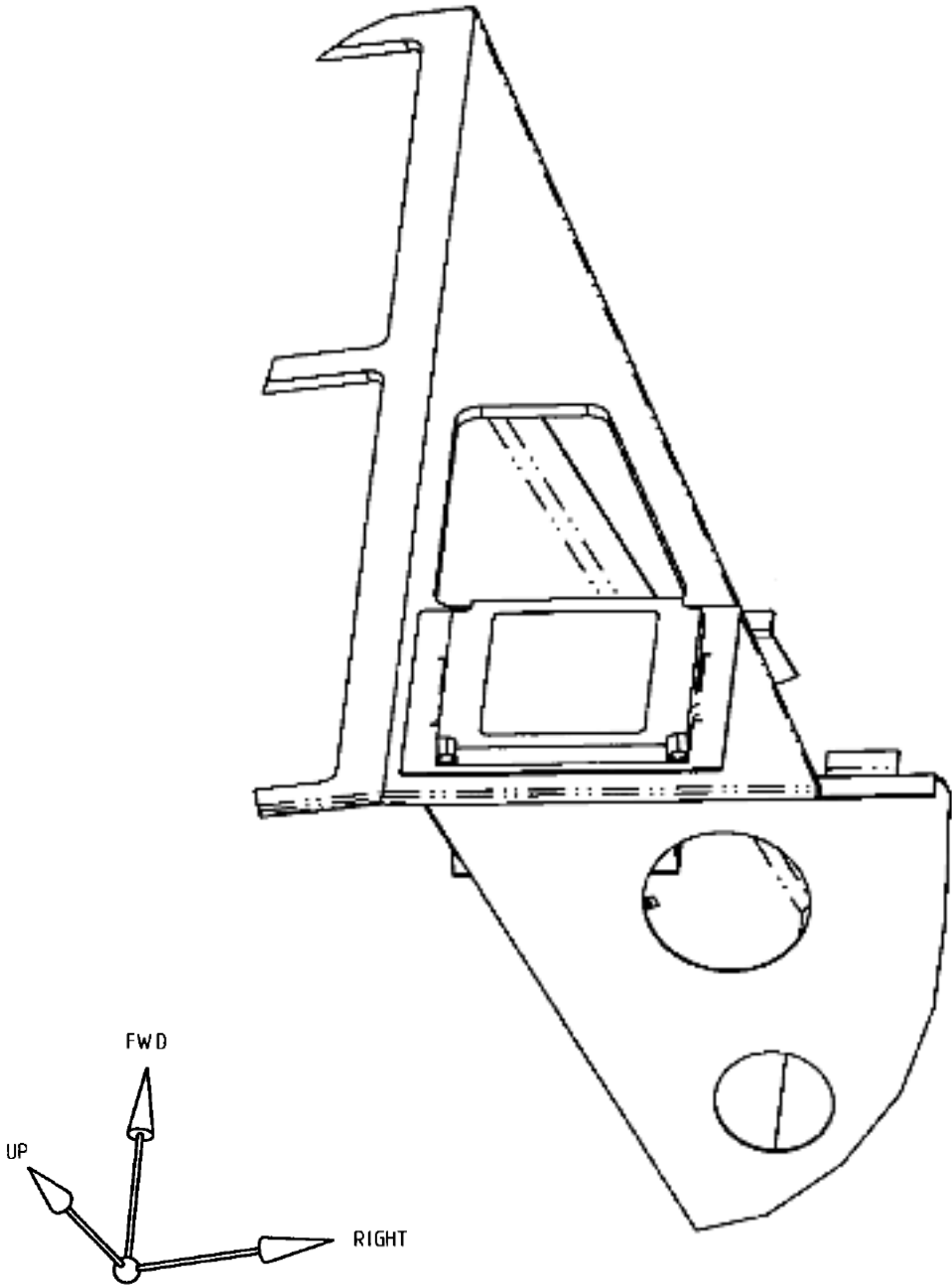

FIGURE 5 - CDMS MONITOR INSTALLATION, CO-PILOT

ST02612CH

FAA Supplemental Type Certificate

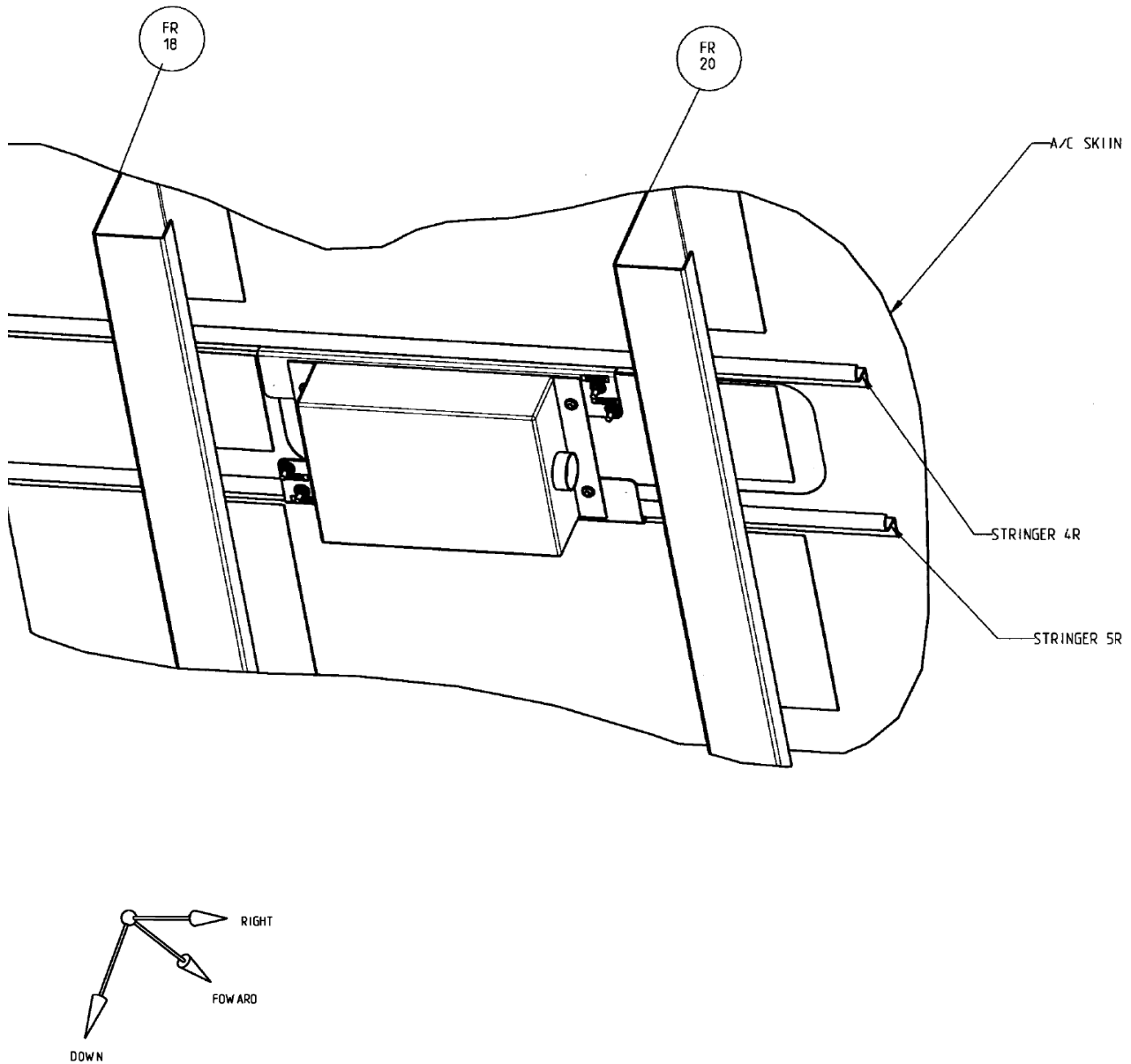

FIGURE 6 - CDMS VIDEO SWITCH INSTALLATION

ST02612CH

FAA Supplemental Type Certificate

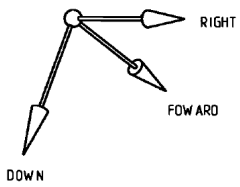
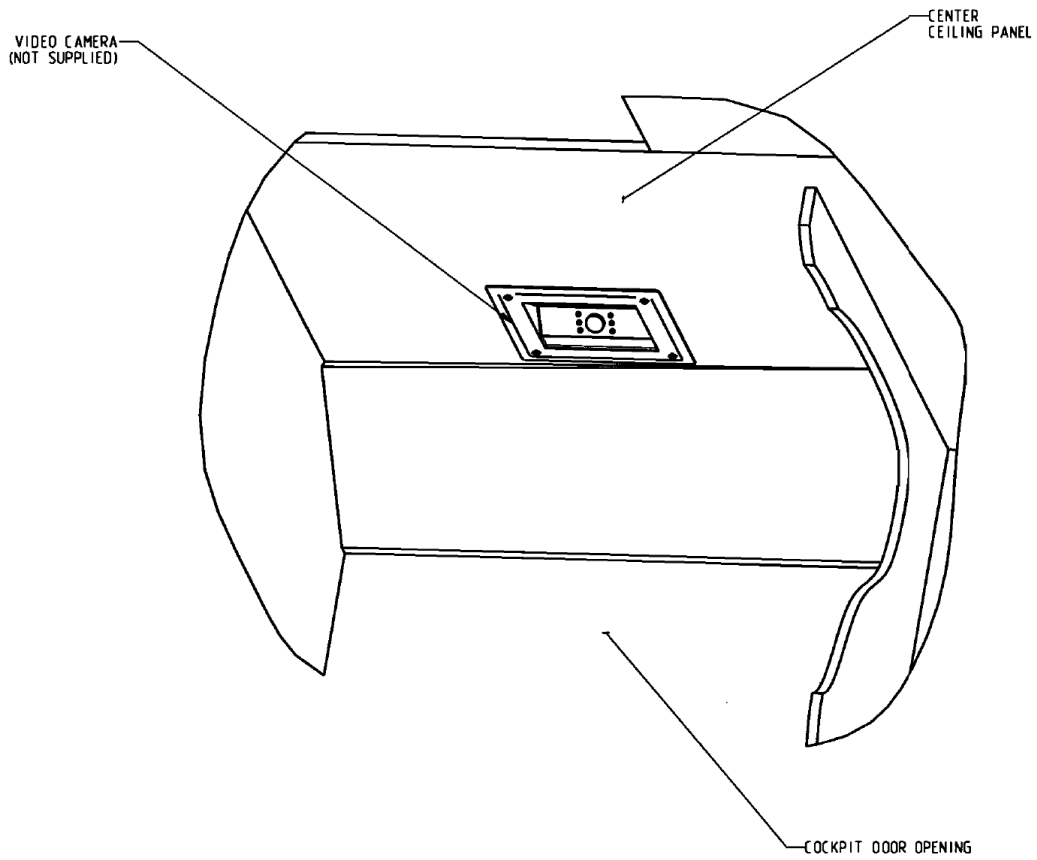

FIGURE 7 - CDMS VIDEO CAMERA 2 INSTALLATION

ST02612CH

FAA Supplemental Type Certificate

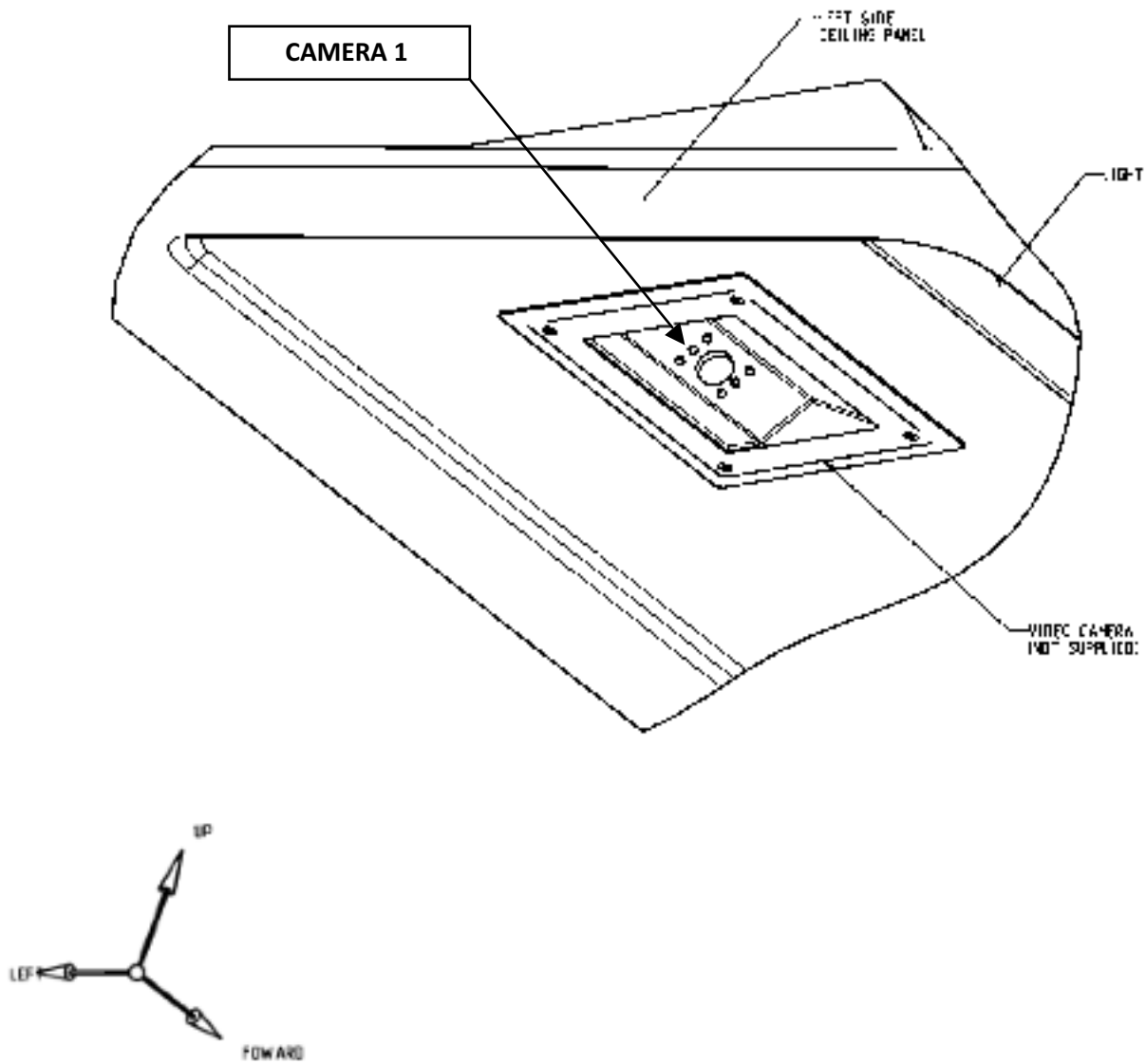

FIGURE 8 - CDMS VIDEO CAMERA 1 INSTALLATION

ST02612CH

FAA Supplemental Type Certificate

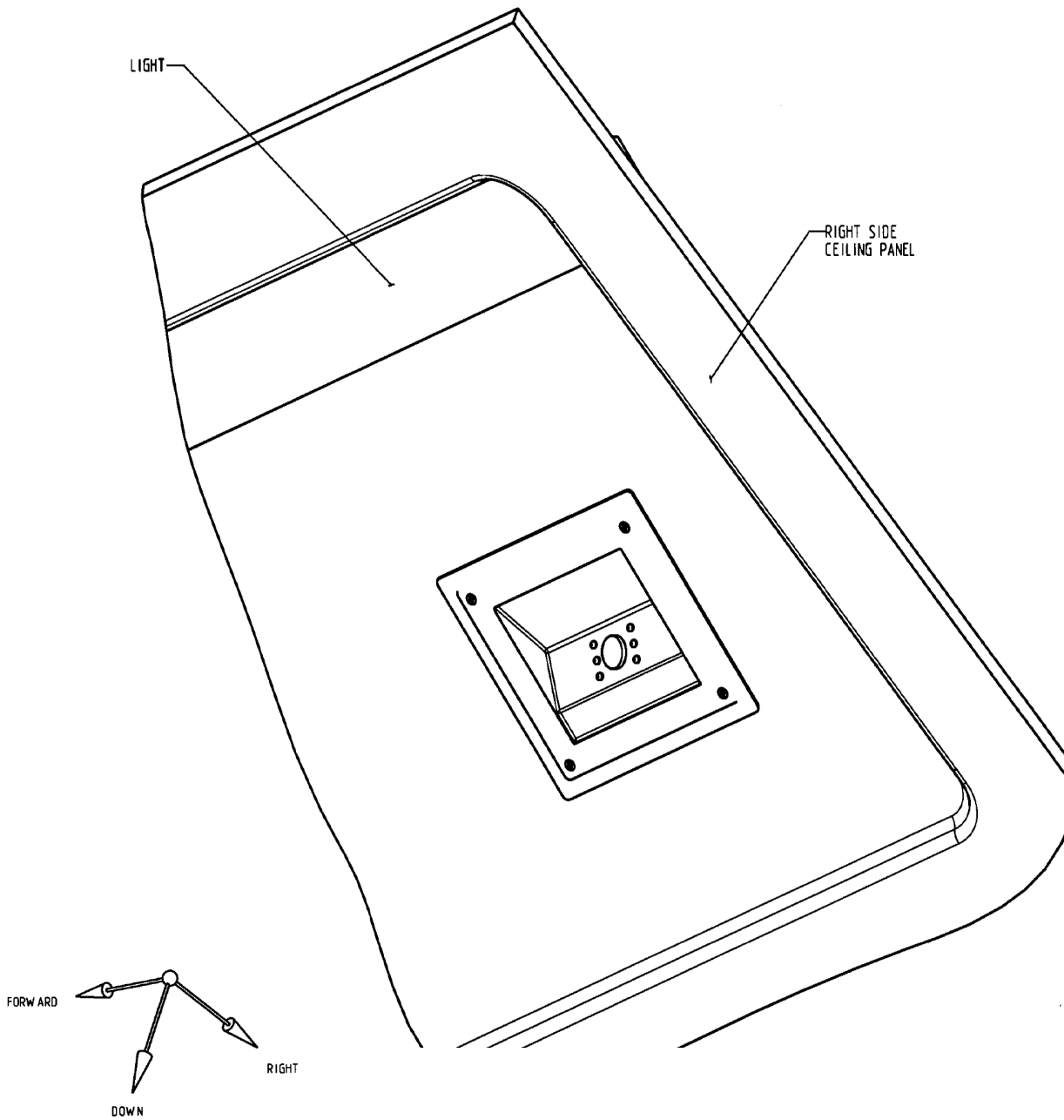

FIGURE 9 - CDMS VIDEO CAMERA 3 INSTALLATION

CONNECT WITH US TODAY

See CarlisleIT's line of **Certification Services** at:
CarlisleIT.com/services/certification-stc-engineering

(+1) 904-494-0549
Sales@CarlisleIT.com