

4

3

2

1



REVISIONS			
REV.	DESCRIPTION	DATE	APPROVED
-	INITIAL RELEASE	07/03/2018	MM
1	UPDATED PART NUMBER	10/24/2018	DL
2	ADDED SHEET 2 PCB DEFINITION	2/15/2019	PV
3	ADDED SECTION VIEW	3/7/2019	PV
4	REVISED MODEL	11/19/2019	PV
5	ADD MISSING DIM.	6/24/2020	FY
6	FOOT PRINT UPDATED	1/24/2021	FY
7	ADD DIMENSION 0.06±0.02	9/3/2021	FY
8	REVISED THE TOLERANCE IN SECTION A	9/8/2021	JZ
9	ADD MOUNTING SCREWS INFO TO TABLE	9/15/2021	JZ

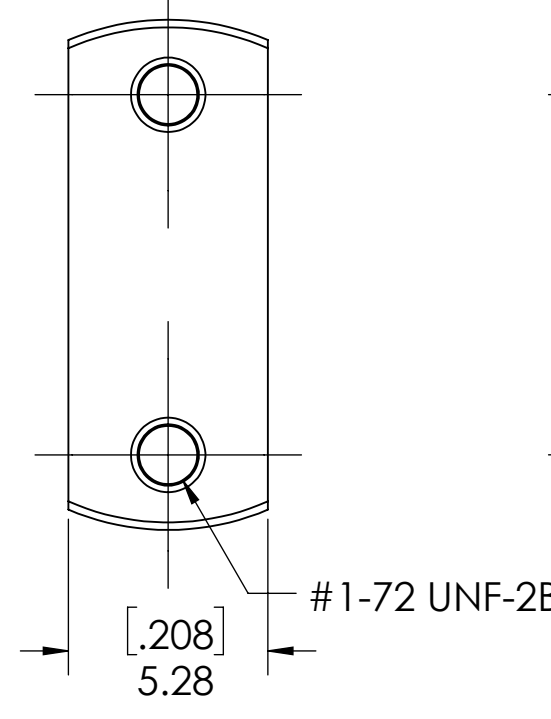
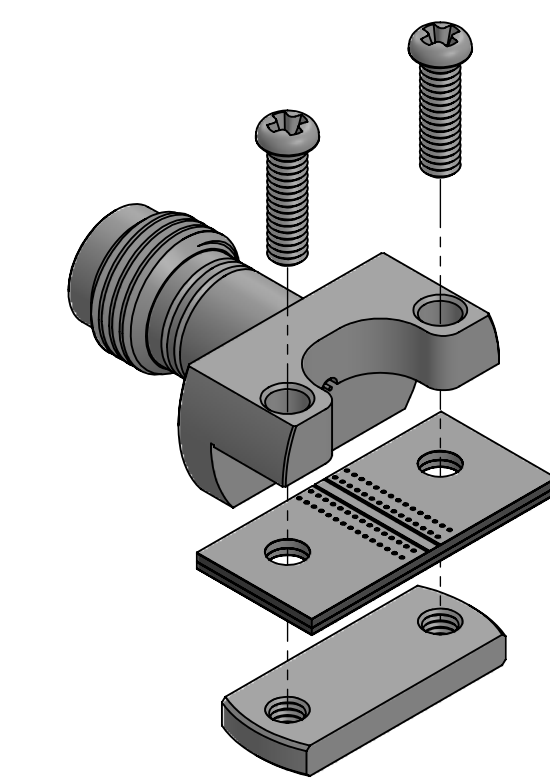
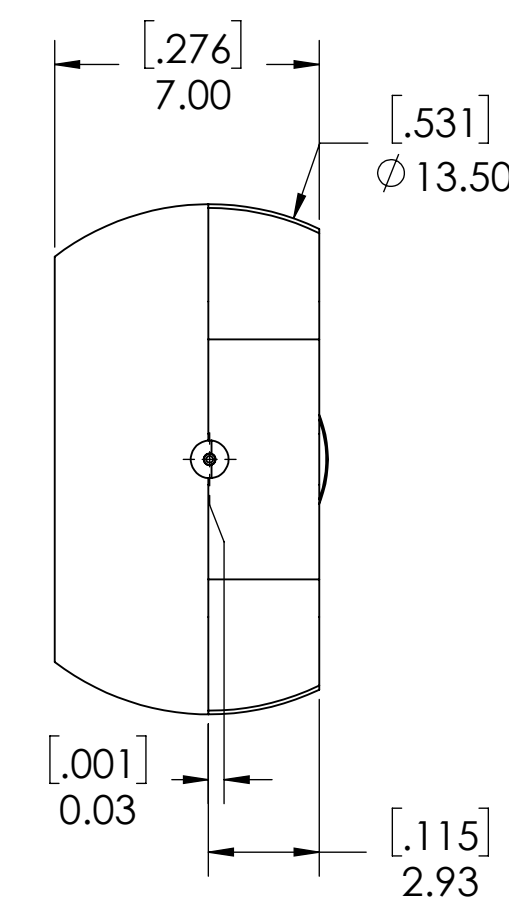
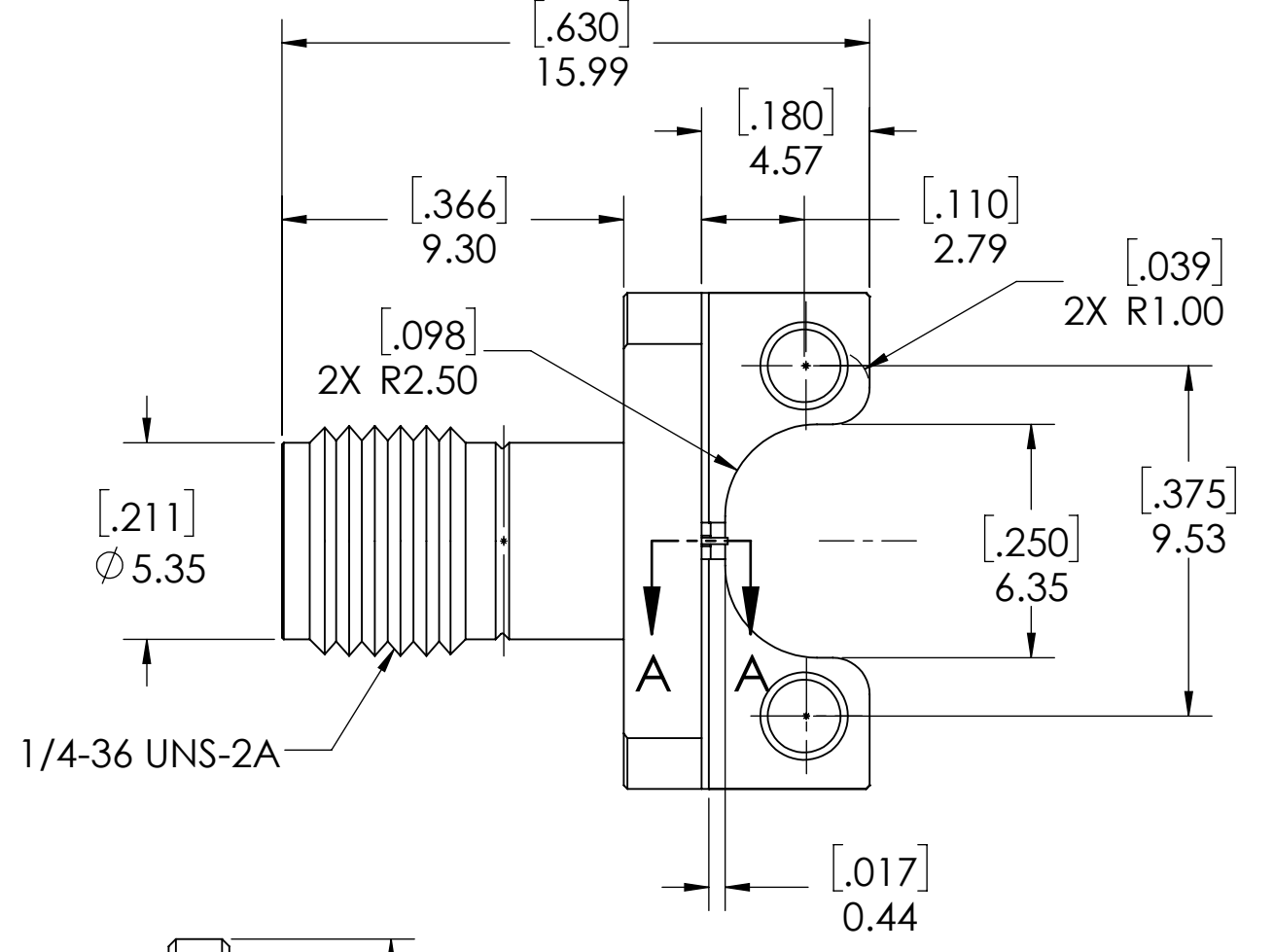
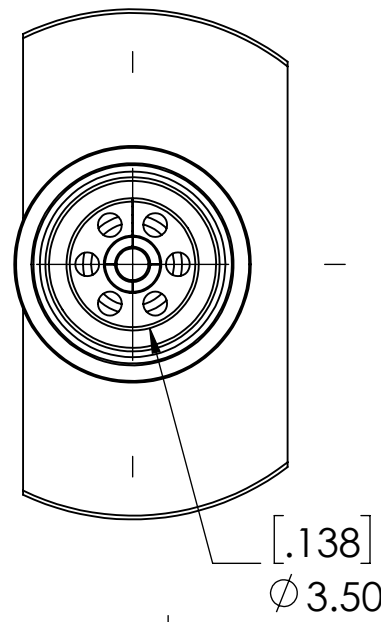

LOCKING BLOCK

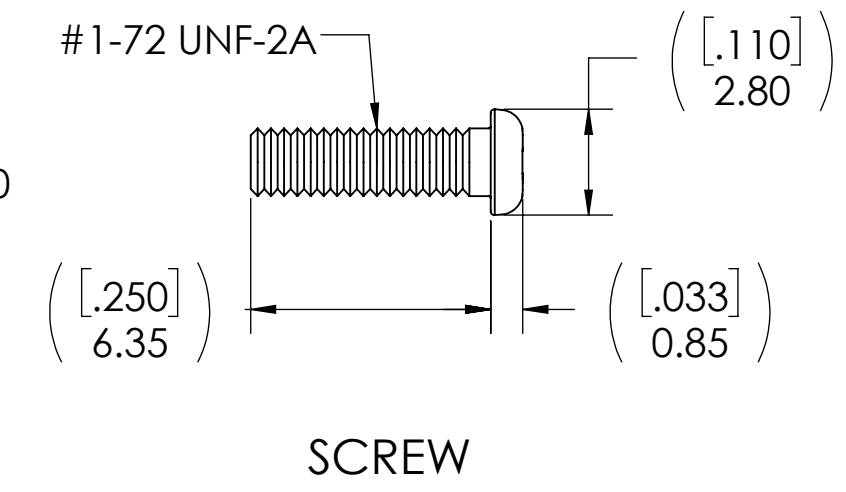

SCREW

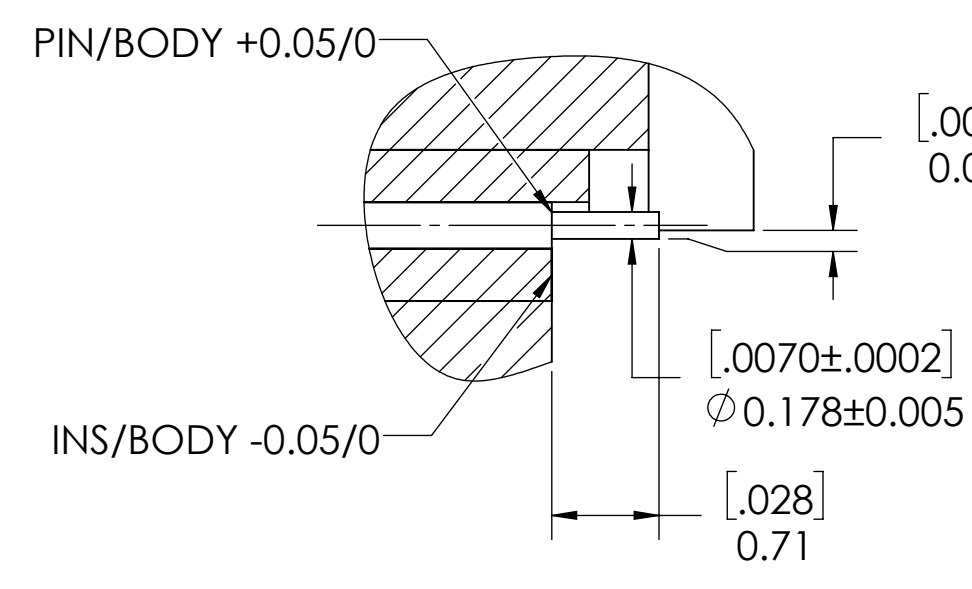

SECTION A-A
SCALE 20 : 1

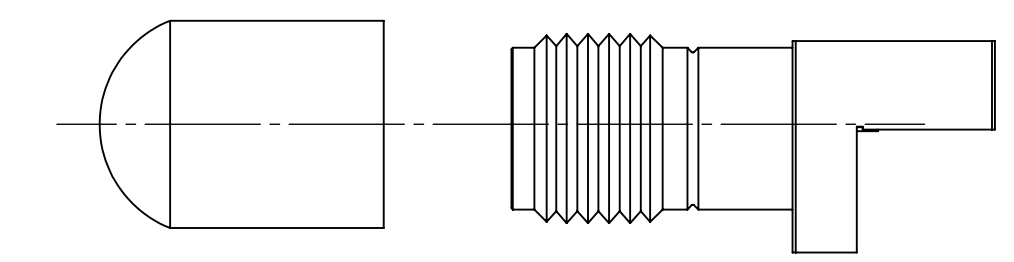

PROTECTION CAP

- NOTE(S):
- These characteristics are typical and for reference.
 - DYH: 58-20003-44070
 - See sheet 2 for PCB interface definition.

MATERIAL(S) :	ELECTRICAL(S) :	MECHANICAL(S) :	ENVIRONMENTAL(S) :
Body: Stainless Steel Center Conductor: Beryllium Copper Insulator: Insulator 1: PCTFE, white Insulator 2: PTFE, white RoHS Compliant Protective Cap: Soft PVC Color: White Mounting Screws: Stainless Steel	Impedance: 50 Ohms Nominal Frequency Range: DC to 34 GHz VSWR: 1.3:1 max at 34 GHz Working Voltage: 400 Vrms max @ Sea Level Dielectric Withstand Voltage: 500 Vrms max. Insulation Resistance: 5000 Megaohms min. Contact Resistance: Initial: Center Contact: 1.5 Milliohms max Outer Contact: 0.8 Milliohms max	Mating Characteristics: Interface per MIL-STD-348 Force to Engage & Disengage: Torque: 2 inch-pounds max Longitudinal Force: NA Connector Durability: 500 Cycles min. Permeability: Less than 2.0 mu. Center Contact Retention: Axial Force: 6 pounds min. Radial Force: NA	Temperature Range: -55°C to +120°C Moisture Resistance: MIL-STD-202, Method 103, Test Condition B Corrosion: MIL-STD-202, Method 101, Test Condition B Vibration: MIL-STD-202, Method 204, Test Condition A Shock: MIL-STD-202, Method 213, Test Condition 1

FINISH(ES) :	APPLICABLE CARLISLE IT DOCUMENTS			TOLERANCES AND NOTES EXCEPT AS NOTED	APPROVAL	INITIALS	DATE	DRAWN BY	CHECKED BY	DESIGN ENG	APPR BY	TITLE	SCALE	SUB-DIRECTORY/ _OUTLINE/	SHEET 1 OF 1	REV. 9
	WORK STANDARD	PROD INSTRUC	ASSY INSTRUC													
Body: Passivated Center Conductor: Gold Plating Mounting Screws: Passivated	NA	NA	NA	THIRD ANGLE PROJECTION SCALE 5:1 DIMENSIONS ARE IN [INCHES] MM ANGLES ±2° .XX DECIMALS ±.063 .XXX DECIMALS ±.01			07.03.18	MM	KM			3.50mm STRAIGHT JACK, EDGE MOUNT (SOLDERLESS)	5:1			
NOTICE THIS DRAWING EMBODIES A CONFIDENTIAL PROPRIETARY DESIGN ORIGINATED BY CARLISLE INTERCONNECT TECHNOLOGIES & ALL DESIGN, MANUFACTURING, REPRODUCTION, USE & SALE RIGHTS REGARDING THE SAME ARE EXPRESSLY RESERVED. IT IS SUBMITTED UNDER A CONFIDENTIAL RELATIONSHIP FOR A SPECIFIED PURPOSE & THE RECIPIENT AGREES BY ACCEPTING THIS DRAWING NOT SUPPLY OR DISCLOSE ANY INFORMATION REGARDING IT TO ANY UNAUTHORIZED PERSON TO INCORPORATE IN OTHER PROJECTS ANY SPECIAL FEATURES PECULIAR TO THIS DESIGN. ALL PATENT RIGHTS HERETO ARE EXPRESSLY RESERVED BY CARLISLE INTERCONNECT TECHNOLOGIES, CERRITOS, CALIFORNIA 90703													 Dongguan City, Guangdong P.R. China 523533			
													DRAWING NO. TMB-E5F2-1L1			

4

3

2

1

4 3 2 1

D

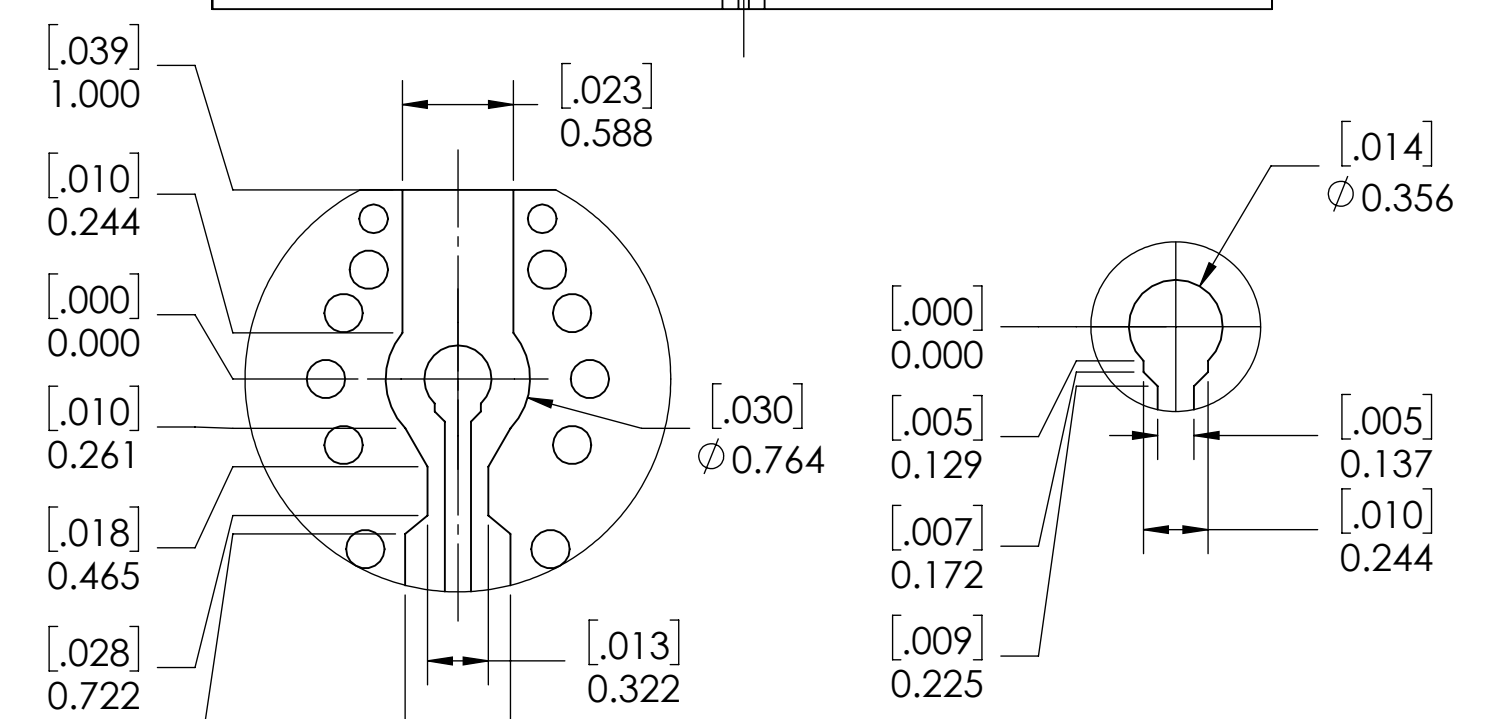
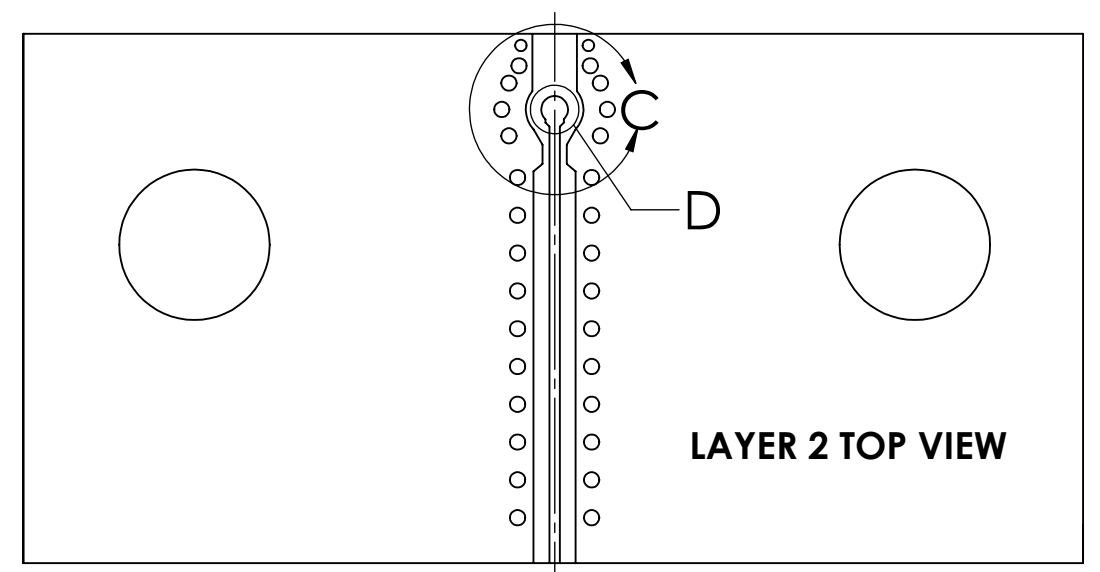
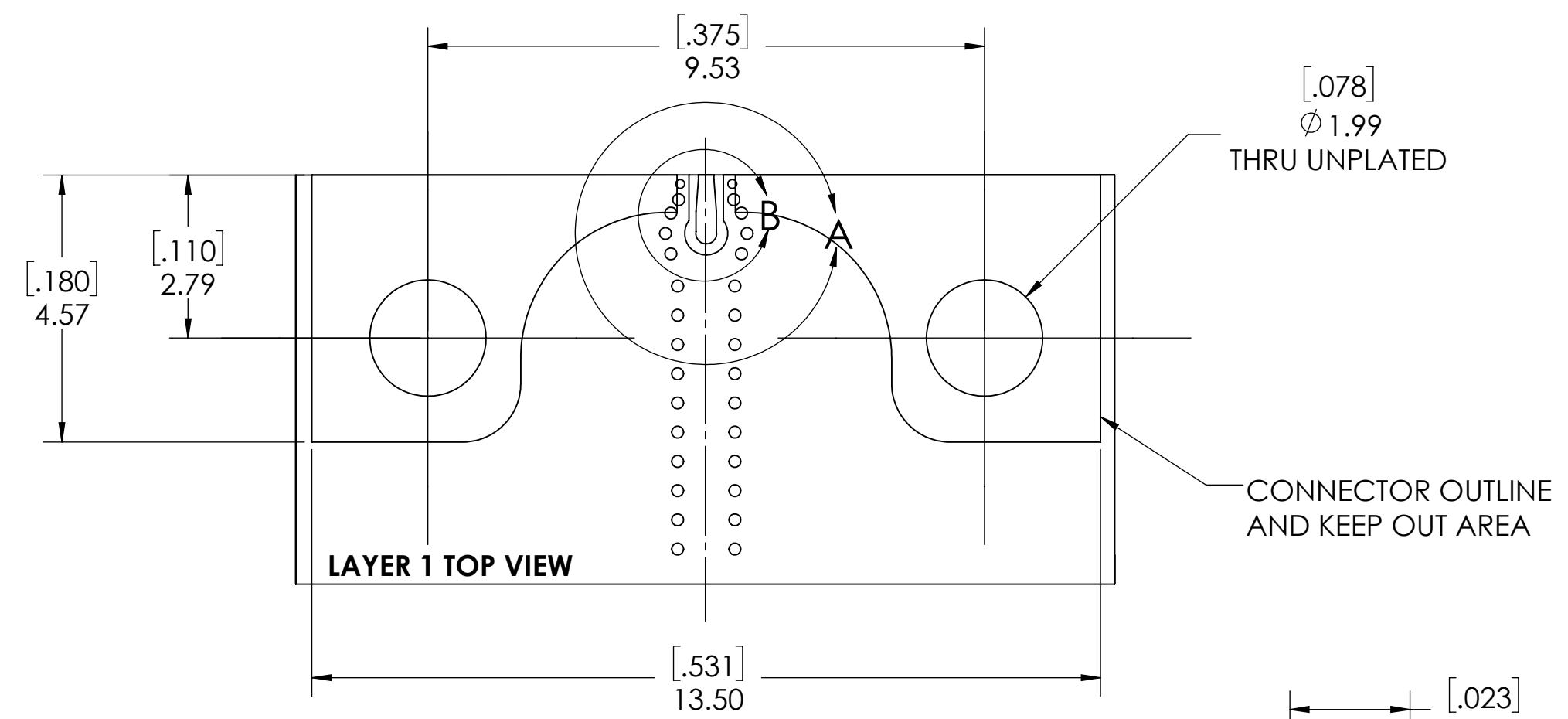

C

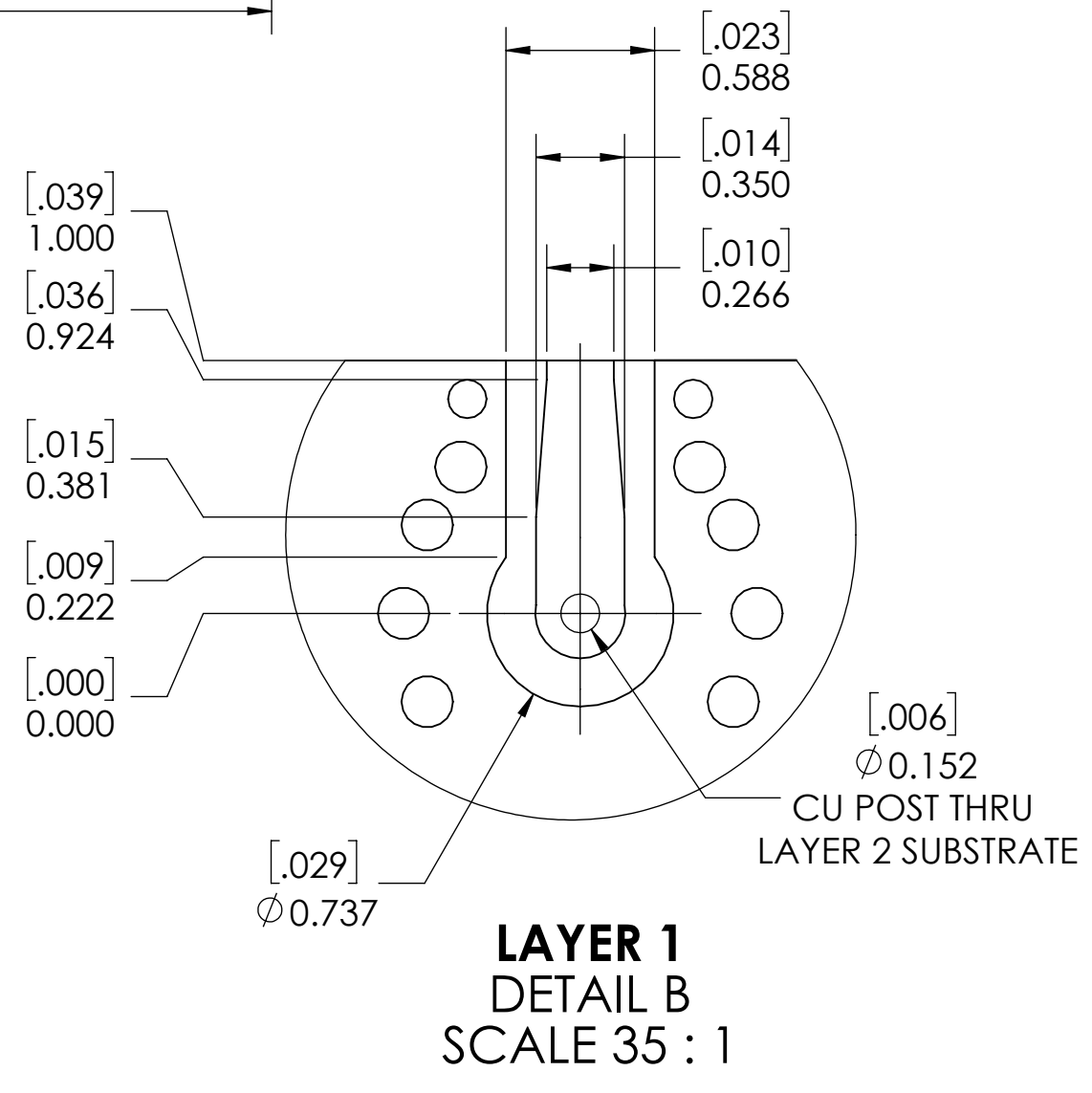
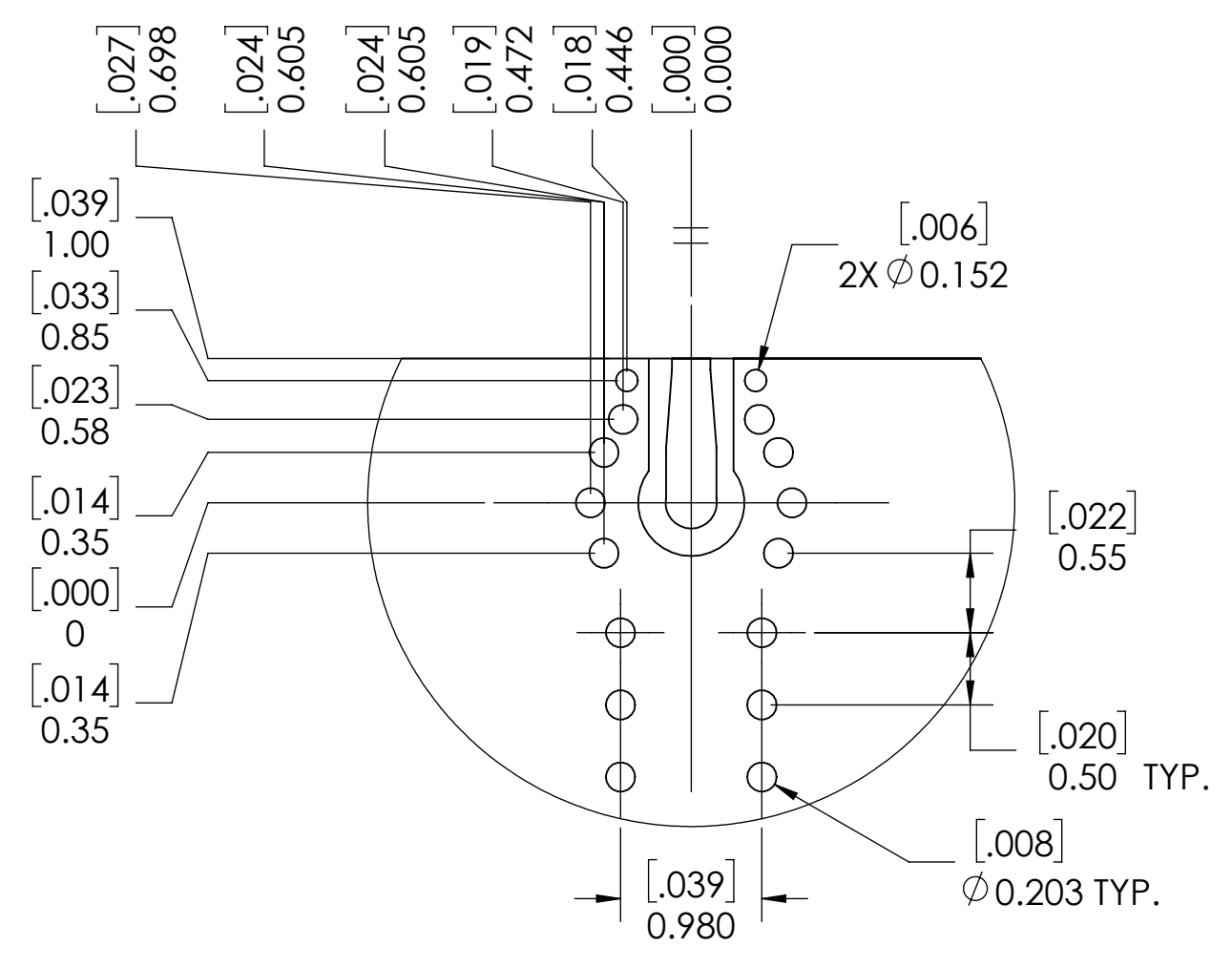

B

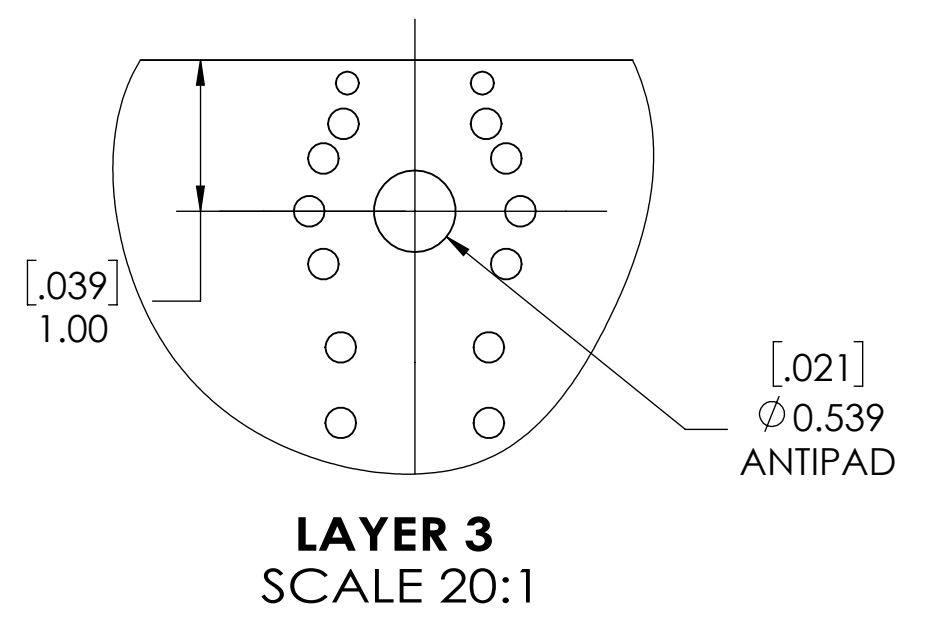

A

FOOTPRINT OF STRIPLINE (REF ONLY)

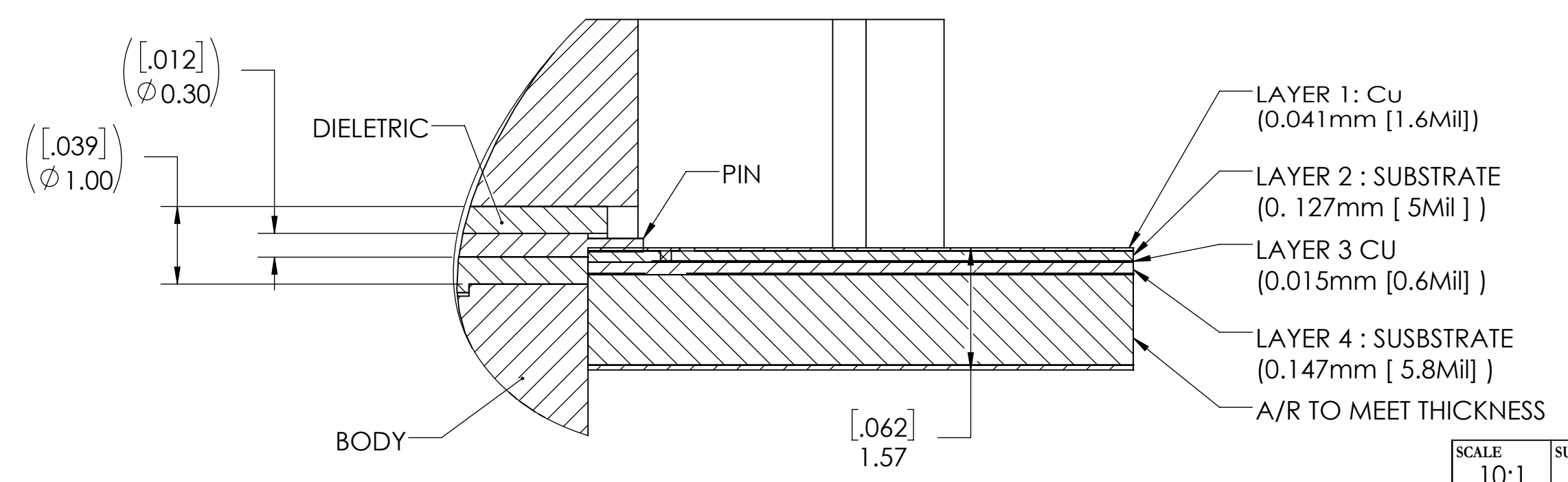

SCALE	SUB-DIRECTORY/	SHEET 2 OF 3
10:1		
SIZE	CAGE CODE	DRAWING NO.
C		TMB-E8F2-1L1
		REV. 9

ENG-SW REV. E 4 3 2 1

4

3

2

1

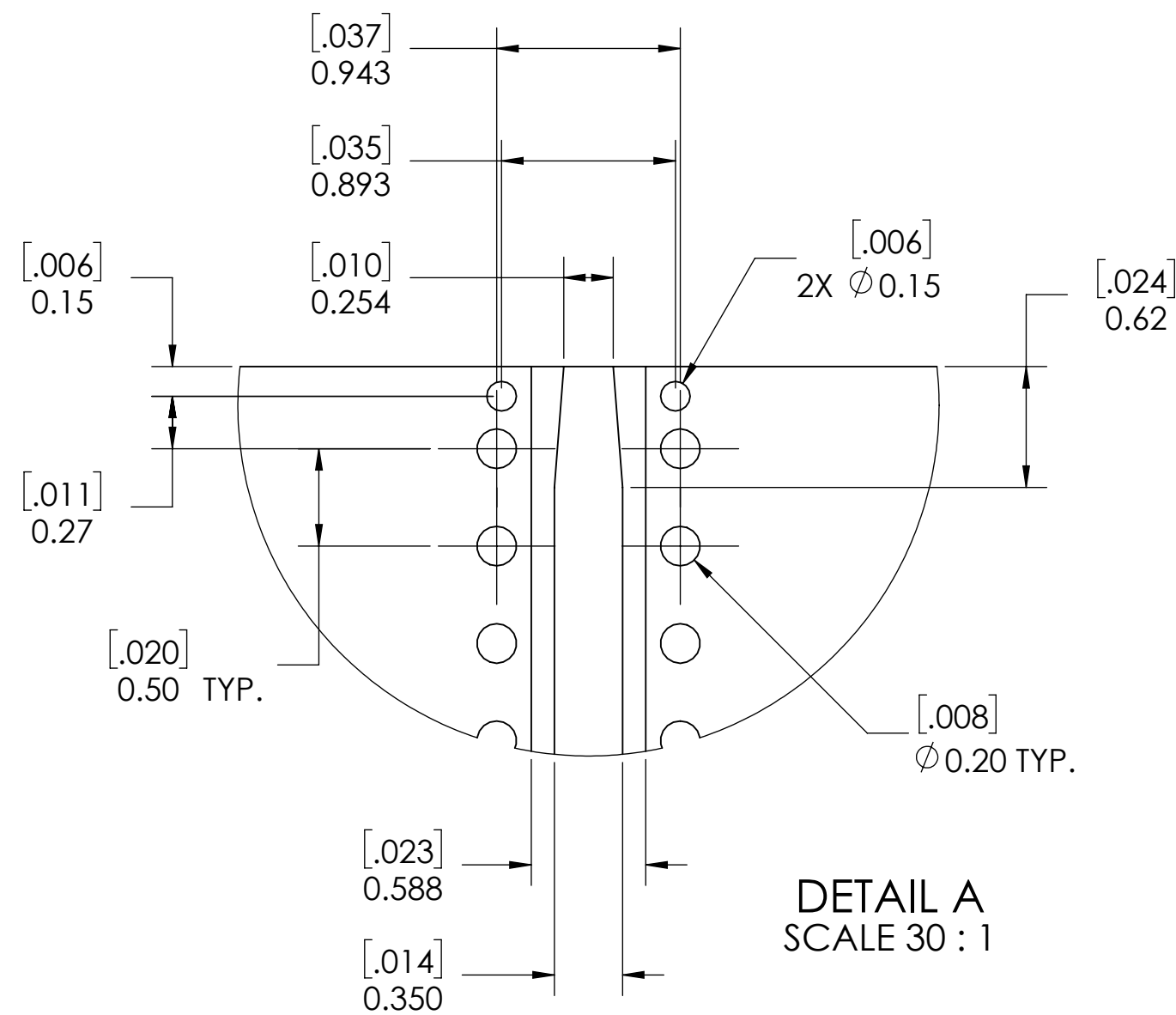

DETAIL A
SCALE 30 : 1

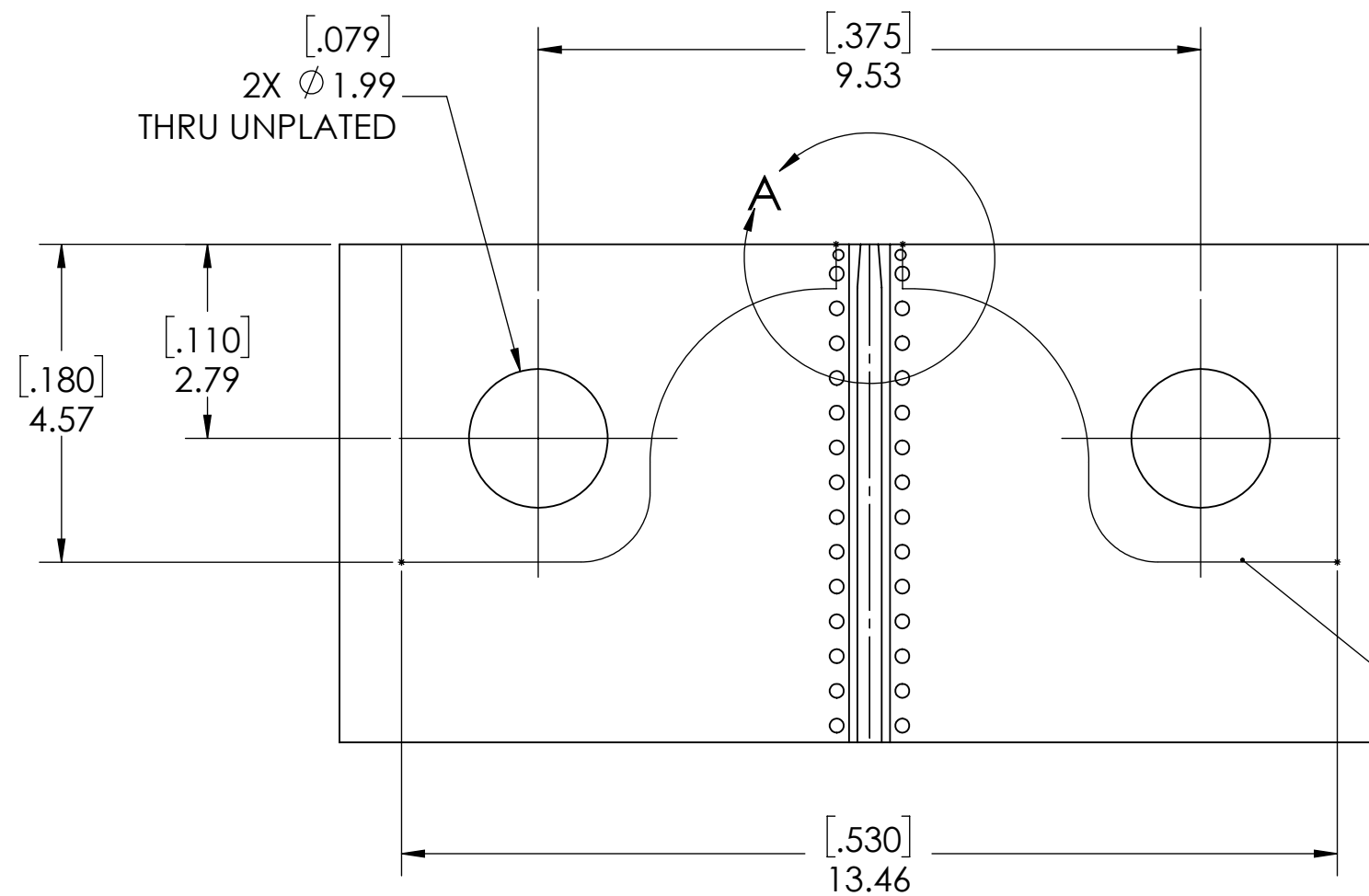

LAYER 3 CUTOUT

CONNECTOR OUTLINE
AND KEEP OUT AREA

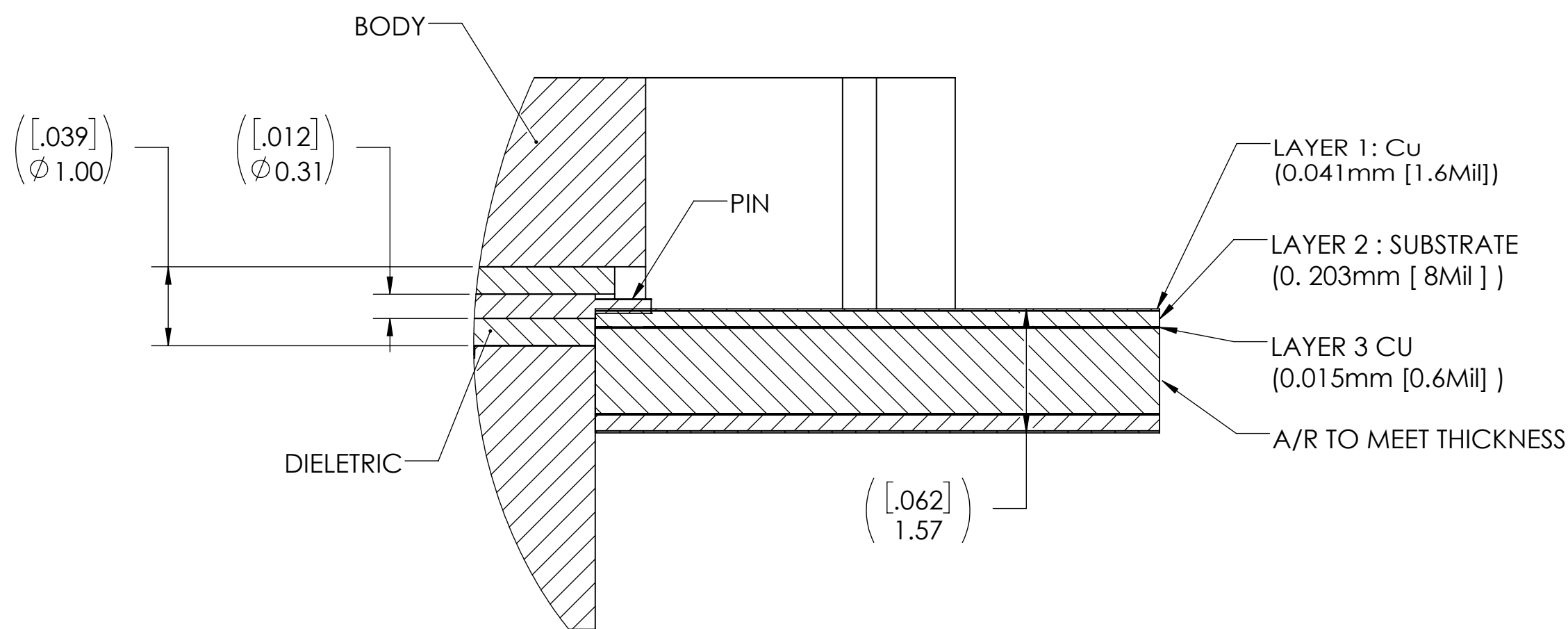
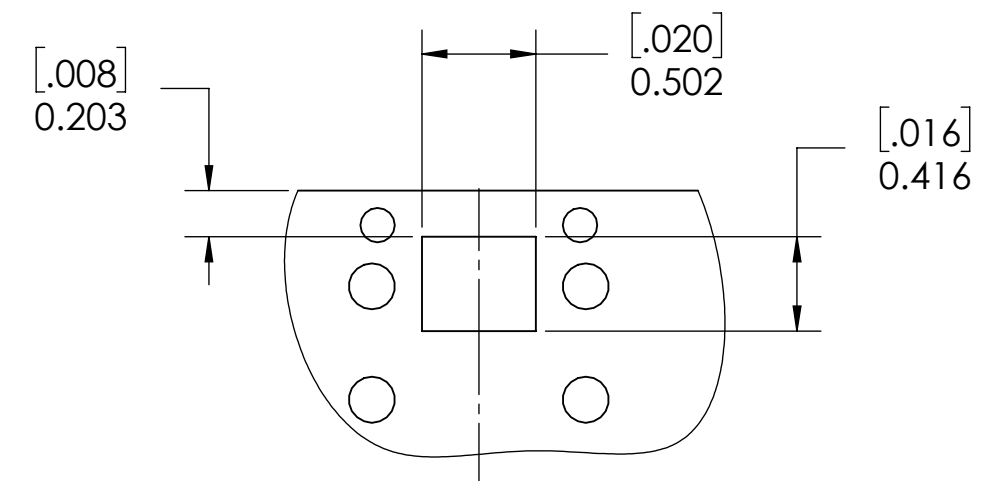

FOOTPRINT OF CPW
(REF ONLY)

SCALE	SUB-DIRECTORY/	SHEET 3 OF 3
10:1		
SIZE	CAGE CODE	DRAWING NO.
C		TMB-E8F2-1L1
		REV. 9

4

3

2

1