

## Insertion-Extraction Hold-Down



Insertion-Extraction Hold-Down

### CONSTRUCTION

#### Materials

- » Composite knob
- » Aluminum cup, hinge, and extractor with anodize finish
- » Aluminum shaft with anodize finish and dry film lubrication
- » RoHS compliant

#### Fasteners

- » Installation via #6-32 (.138-32) UNC screws using standard tooling

### SPECIFICATIONS

#### Performance Standards

- » BPS-C-157
- » RTCA/DO-160G

#### Designed for use with Equipment

- » ARINC 404A
- » ARINC 600
- » ARINC 628
- » ARINC 704A
- » ARINC 738A-1

#### Weight

- » 41g

### FUNCTION & BENEFITS

#### Function

- » Force limiting clutch
- » Jammed mechanism release per ARINC 600
- » 7/8" socket drive body
- » Minimum 1/2" extraction of LRU



Lightweight Tray with Insertion-Extraction Hold-Downs

# Insertion-Extraction Hold-Down

Note: Dimensions are in inches, bracketed [numbers] represent millimeters.

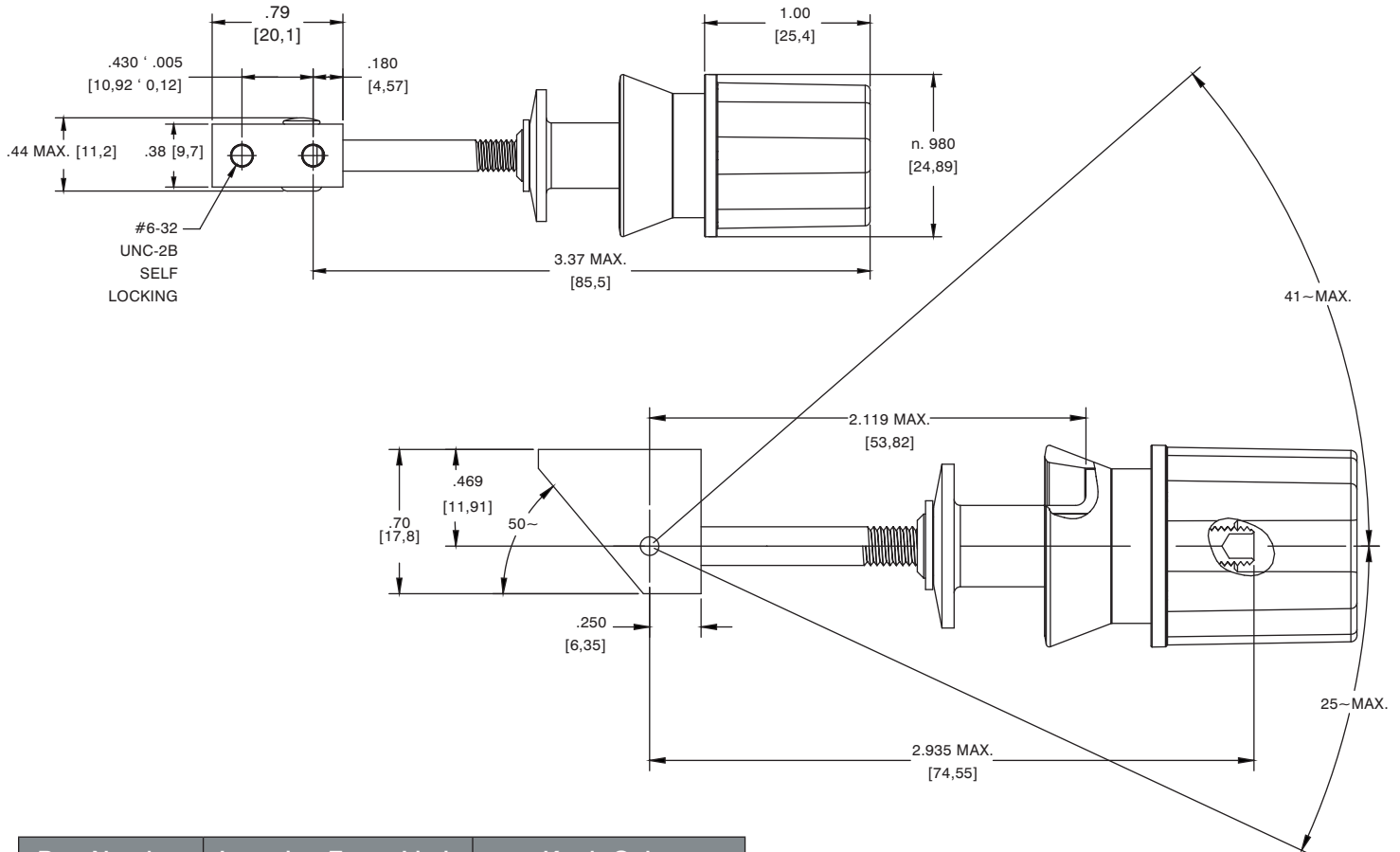

Part Number	Insertion Force Limit	Knob Color
200-33899-101	140±40 lbs	Black

## TESTED TO MEET THE FOLLOWING REQUIREMENTS

### Operational Shock

- » RTCA/DO-160G section 7.2.1, 6 g 11 ms terminal sawtooth (3 shocks in all 6 directions)

### Crash Safety Impulse

- » RTCA/DO-160G section 7.3.1, 20 g (1 shock in all 6 directions)

### Crash Safety Sustained

- » RTCA/DO-160G section 7.3.3, 20 g (3 seconds minimum in all 6 directions)

### Robust Vibration

- » RTCA/DO-160G section 8.7.2, Random Category R, Curve B3 & B4

### High Power Short Duration Engine Imbalance

- » RTCA/DO-160G section 8.6, Sinusoidal Category H, Curve R

### Mechanical Endurance

- » 250 Cycles Minimum



See CarlisleIT's line of Trays, Racks and Enclosures at:  
[CarlisleIT.com/products/structures](http://CarlisleIT.com/products/structures)

+1 (800) 458-9960  
[Sales@CarlisleIT.com](mailto:Sales@CarlisleIT.com)