

**** EXPORT CONTROLLED DOCUMENT - EAR ****
 The information in this document is subject to the Export Controls in Accordance with the Export Administration Regulations. Diversion Contrary to U.S. Law is prohibited.

This print and associated documents and the contained information are the confidential property of CARLISLE INTERCONNECT TECHNOLOGIES. Disclosure of, and/or reproduction of, all or part thereof or manufacture of any part from information contained on this print not specifically permitted by CARLISLE INTERCONNECT TECHNOLOGIES in writing is forbidden.

CAD GENERATED DOCUMENT
 ANY CHANGES TO THIS DOCUMENT MUST BE SUBMITTED TO THE DESIGN/DRAFTING DEPARTMENT FOR PROPER UPDATE.

EDN	SHEET	ZONE	REV.	REF DESCRIPTION (SEE EDN FOR COMPLETE CHANGE DETAILS)	DATE	APPROVED
72355			NC	NEW RELEASE	8/21/18	R LAY
72745		TB	A	ADDED "DUAL ATG/DIRECTIONAL" TO TITLE.	9/26/18	R LAY
73017	1	NTS	B	ADDED FLAG NOTE 7	11/13/18	R. Lay
	3	D4		ADDED D, E AND F TO CABLE CONFIGURATION		
	4	FOV		SEE SHEET 5 WAS SEE SHEET 4		
	4	FOV		ADDED NEW SHEET 4		
	5	FOV		ADDED NEW D, E AND F CABLE CONFIGURATION MOVED SHEET 4 CONTENT TO SHEET 5		



NOTES: UNLESS OTHERWISE SPECIFIED

- LABEL CABLES AND INSTALL BLACK ADHESIVE SHRINK TUBING ON CONNECTORS PER ECS WORK INSTRUCTION W1007. INFORMATION IN PARENTHESIS IS NOT PART OF LABEL.
- COAXIAL CABLE ASSEMBLY LENGTH TOLERANCE, UNLESS OTHERWISE NOTED;

LENGTH	≤ 12	>12 ≤ 120	> 120
TOL	+0.5/-0.0	+3.5/-0.0	+5.5/-0.0
- TEST TO BE PERFORMED PER M1305 AND THE FOLLOWING:
 TEST CABLES WITH MARKER SET AT 900 MHz.
 ATTENUATION: < 3 dB FOR EACH CABLE.
 VSWR: ≤ 1.35:1 FOR EACH CABLE.
- INCLUDE APPROPRIATE TEST DOCUMENTATION WITH EACH SET.
 - 5 IF USING 311901, 421601, 311601 OR 311501 A 1 INCH PIECE OF RED HEAT SHRINK P/N ST22138-RED OR ALT P/N STS22138-RED OR M23053/5-107-2 SHALL BE USED ON -01, -03, -05 AND -07. A 1 INCH PIECE OF BLUE HEAT SHRINK P/N ST22138-BLU OR ALT P/N STS22138-BLU OR M23053/5-107-6 SHALL BE USED ON -02, -04, -06 AND -08. INSTALL COLORED HEAT SHRINK PER W1007.
 - 6 IF USING 421201 OR 311201 A 1 INCH PIECE OF RED HEAT SHRINK P/N ST22112-RED OR ALT P/N STS22112-RED OR M23053/5-108-2 SHALL BE USED ON -01, -03, -05 AND -07. A 1 INCH PIECE OF BLUE HEAT SHRINK P/N ST22112-BLU OR ALT P/N STS22112-BLU OR M23053/5-108-6 SHALL BE USED ON -02, -04, -06 AND -08. INSTALL COLORED HEAT SHRINK PER W1007.
 - 7 DO NOT TERMINATE CONNECTOR. TERMINATE CONTACT FOR TESTING. AFTER TESTING, REMOVE CONNECTOR AND COVER CONTACT WITH HEAT SHRINK. BAG CONNECTOR AND HEAT SHRINK AND SHIP WITH CABLE ASSEMBLY.

1	500-104821-XXX-XX-08	AFT ATG COAX CABLE J3	8
1	500-104821-XXX-XX-07	AFT ATG COAX CABLE J4	7
1	500-104821-XXX-XX-06	AFT ATG COAX CABLE J1	6
1	500-104821-XXX-XX-05	AFT ATG COAX CABLE J2	5
1	500-104821-XXX-XX-04	FWD ATG COAX CABLE J3	4
1	500-104821-XXX-XX-03	FWD ATG COAX CABLE J4	3
1	500-104821-XXX-XX-02	FWD ATG COAX CABLE J1	2
1	500-104821-XXX-XX-01	FWD ATG COAX CABLE J2	1
QTY REQ'D	COMPONENTS PART NO.	NOMENCLATURE	
XXXXX/XXXXX	OR IDENTIFYING NO.	OR DESCRIPTION	
KIT PART NO.			

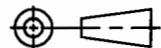
PART LIST

UNLESS OTHERWISE SPECIFIED: ALL DIMENSIONS ARE IN INCHES TOLERANCES XX & XX XXX & .01	ALL LENGTHS IN INCHES DRAWN C CHAPMAN 7/12/18 CHECKED R LAY 8/21/18 DESIGNED C CHAPMAN 7/12/18 THIRD ANGLE PROJECTION PROJCTY R LAY 8/21/18 MANUFACTURING S SKIBINSKI 8/23/18 ENGINEERING		 Carlisle Interconnect Technologies Franklin, WI 53132 414-421-5300	TITLE: AVANCE L5 DUAL ATG/DIRECTIONAL ANTENNA COAX ASSEMBLY KIT SIZE: C66197 CASE CODE: 66197 LEVEL: 1 DRG NO.: 500-104821 SCALE: NONE EFFECTIVITY: NONE SHEET: 1 OF 5
---	---	---	--	---

4

3

2

1

**** EAR CONTROLLED ****

DUAL ATG/DIRECTIONAL ANTENNA INSTALLATION

EXAMPLE KIT PART NUMBER

P/N 500-104821-3202A/2401A

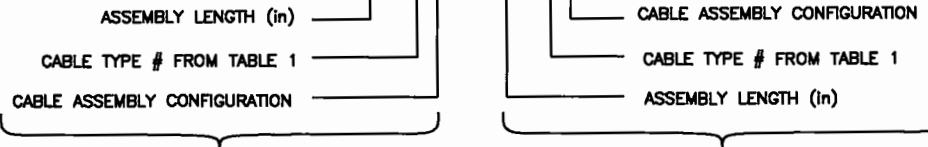

FWD ANTENNA CABLES
INCLUDES 01 THRU 04
SEE SHEET 3.

AFT ANTENNA CABLES
INCLUDES 05 THRU 08
SEE SHEET 3.

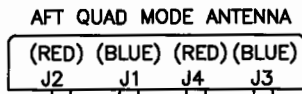
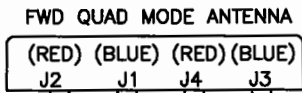

AVANCE L5



500-104821-XXX-XX-01

500-104821-XXX-XX-02

500-104821-XXX-XX-03

500-104821-XXX-XX-04

500-104821-XXX-XX-05

500-104821-XXX-XX-06

500-104821-XXX-XX-07

500-104821-XXX-XX-08

CARLISLE		Carlisle Interconnect Technologies	
		Franklin, WI 53132	
		414-421-5300	
SIZE	DATE CODE	LEVEL	DRG. NO.
C	66197		500-104821
SCALE	APPROPRIATE	NONE	SHEET 2 OF 5

4

3

2

1

**** EAR CONTROLLED ****

CABLE ASSEMBLY PART NUMBER

P/N 500-104821-XXX-XX-XX (ALL LENGTHS IN INCHES)

ASSEMBLY LENGTH
 CABLE TYPE # FROM TABLE 1
 CABLE ASSEMBLY CONFIGURATION
 A, B, C, D, E OR F SEE TABLE 2

01,02,03,04,05,06,07,08 (SEE EXAMPLE BELOW)

EXAMPLE : 500-104821-320-2A-01 = 320" ASSEMBLY OF 421601 WITH TWO CTS922 CONNECTORS ON EACH END USED FOR FWD ATG ANTENNA J2.

CABLE ASSEMBLY CONFIGURATIONS

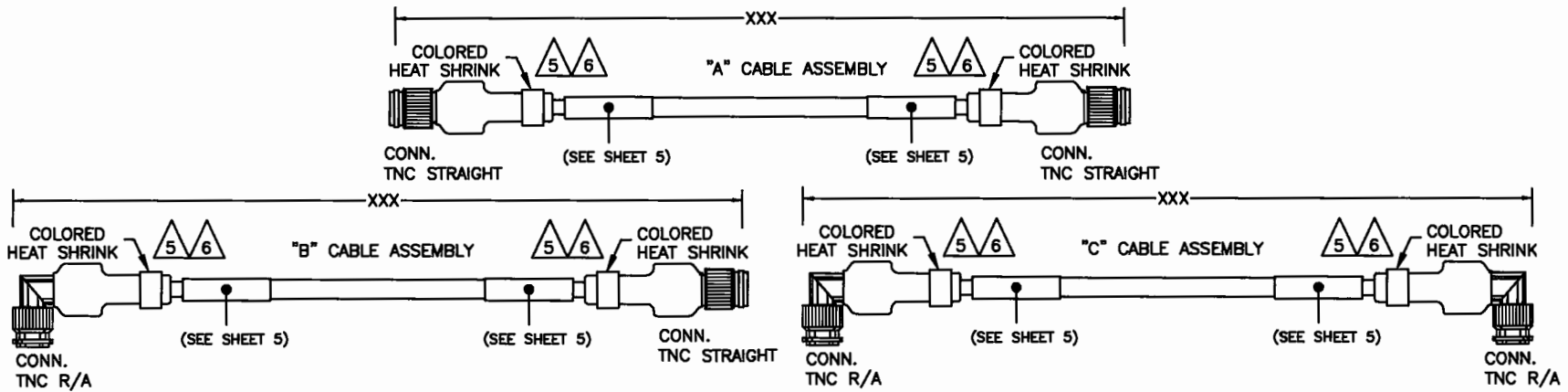

TABLE 2 (COAX CONNECTOR & LABELS)

TABLE 1 (COAX CABLE TYPE)

6	311201	600 INCHES
	421201	600 INCHES
#	CABLE TYPE	MAXIMUM LENGTH

2	2	2	TMS-SCE-1/2-2.0-9	1/2 INCH HEAT SHRINK (LABEL)
2	1	-	CTR122	RIGHT ANGLE TNC PLUG FOR 421201, 311201
-	1	2	CTS122	STRAIGHT TNC PLUG FOR 421201, 311201
C	B	A	PART NUMBER	DESCRIPTION
CONFIGURATION				

5	4	311501	500 INCHES
	3	311601	420 INCHES
	2	421601	420 INCHES
#	CABLE TYPE	MAXIMUM LENGTH	

2	2	2	TMS-SCE-3/8-2.0-9	3/8 INCH HEAT SHRINK (LABEL)
2	1	-	CTR922	RIGHT ANGLE TNC PLUG FOR 421601, 311601, 311501
-	1	2	CTS922	STRAIGHT TNC PLUG FOR 421601, 311601, 311501
C	B	A	PART NUMBER	DESCRIPTION
CONFIGURATION				

5	1	311901	300 INCHES
	#	CABLE TYPE	MAXIMUM LENGTH

2	2	2	TMS-SCE-3/8-2.0-9	3/8 INCH HEAT SHRINK (LABEL)
2	1	-	CTR722	RIGHT ANGLE TNC PLUG FOR 311901
-	1	2	CTS722	STRAIGHT TNC PLUG FOR 311901
C	B	A	PART NUMBER	DESCRIPTION
CONFIGURATION				

CARLISLE		Carlisle Interconnect Technologies Franklin, WI 53132 414-421-5300	
SIZE	ORIG. CODE	LEVEL	DRG. NO.
C	66197		500-104821
SCALE	EFFECTIVITY	NONE	SHEET 3 OF 5

**** EAR CONTROLLED ****

CABLE ASSEMBLY PART NUMBER

P/N 500-104821-XXX-XX-XX (ALL LENGTHS IN INCHES)

ASSEMBLY LENGTH
 CABLE TYPE # FROM TABLE 1
 CABLE ASSEMBLY CONFIGURATION
 A, B, C, D, E OR F SEE TABLE 2

01,02,03,04,05,06,07,08 (SEE EXAMPLE BELOW)

EXAMPLE : 500-104821-320-2A-01 = 320" ASSEMBLY OF 421601 WITH TWO CTS922 CONNECTORS ON EACH END USED FOR FWD ATG ANTENNA J2.

CABLE ASSEMBLY CONFIGURATIONS

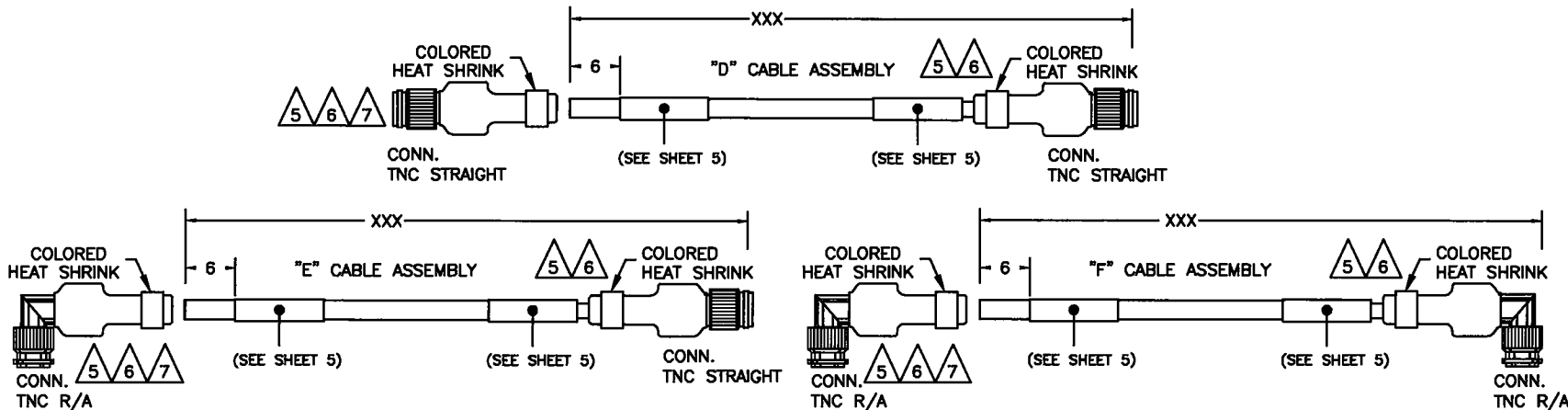

TABLE 2 (COAX CONNECTOR & LABELS)

TABLE 1 (COAX CABLE TYPE)

6	311201	800 INCHES
5	421201	800 INCHES
#	CABLE TYPE	MAXIMUM LENGTH

2	2	2	TMS-SCE-1/2-2.0-9	1/2 INCH HEAT SHRINK (LABEL)
2	1	-	CTR122	RIGHT ANGLE TNC PLUG FOR 421201, 311201
-	1	2	CTS122	STRAIGHT TNC PLUG FOR 421201, 311201
F	E	D	PART NUMBER	DESCRIPTION
CONFIGURATION				

4	311501	500 INCHES
3	311601	420 INCHES
2	421601	420 INCHES
#	CABLE TYPE	MAXIMUM LENGTH

2	2	2	TMS-SCE-3/8-2.0-9	3/8 INCH HEAT SHRINK (LABEL)
2	1	-	CTR922	RIGHT ANGLE TNC PLUG FOR 421601, 311601, 311501
-	1	2	CTS922	STRAIGHT TNC PLUG FOR 421601, 311601, 311501
F	E	D	PART NUMBER	DESCRIPTION
CONFIGURATION				

1	311901	300 INCHES
#	CABLE TYPE	MAXIMUM LENGTH

2	2	2	TMS-SCE-3/8-2.0-9	3/8 INCH HEAT SHRINK (LABEL)
2	1	-	CTR722	RIGHT ANGLE TNC PLUG FOR 311901
-	1	2	CTS722	STRAIGHT TNC PLUG FOR 311901
F	E	D	PART NUMBER	DESCRIPTION
CONFIGURATION				

CARLISLE Carlisle Interconnect Technologies
 Franklin, WI 53132
 414-421-5300

SIZE	DATE CODE	LEVEL	DRG. NO.
C	66197		500-104821
WORLD	EFFECTIVITY	NONE	SHEET 4 OF 5

4

3

2

1

DRG. NO. 500-104821	SHEET 5	REV. B
------------------------	------------	-----------

**** EAR CONTROLLED ****

D

D

CABLE LABELING

500-104821-XXX-XX-01
 SER# EXXXXX
 ATG1 FWD-H1/J2 ANT
 (RED)

500-104821-XXX-XX-02
 SER# EXXXXX
 ATG2 FWD-V1/J1 ANT
 (BLUE)

500-104821-XXX-XX-03
 SER# EXXXXX
 ATG1 RIGHT-H2/J4 ANT
 (RED)

500-104821-XXX-XX-04
 SER# EXXXXX
 ATG2 RIGHT-V2/J3 ANT
 (BLUE)

C

C

500-104821-XXX-XX-05
 SER# EXXXXX
 ATG1 AFT-H3/J2 ANT
 (RED)

500-104821-XXX-XX-06
 SER# EXXXXX
 ATG2 AFT-V3/J1 ANT
 (BLUE)

500-104821-XXX-XX-07
 SER# EXXXXX
 ATG1 LEFT-H4/J4 ANT
 (RED)

500-104821-XXX-XX-08
 SER# EXXXXX
 ATG2 LEFT-V4/J3 ANT
 (BLUE)

B

B

A

A

4

3

2

1

CARLISLE		Carlisle Interconnect Technologies Franklin, WI 53132 414-421-5300	
SIZE C	ORDER CODE 66197	LEVEL	DRG. NO. 500-104821
SHEET		PRIORITY NONE	SHEET 5 OF 5