

INTERCONNECT CAPABILITIES

WHEN PERFORMANCE MATTERS

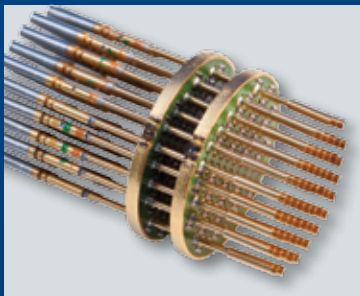

CARLISLE
INTERCONNECT TECHNOLOGIES



Carlisle Interconnect Technologies (CarlisleIT) is one of the world's leading designers and manufacturers of high-performance interconnect solutions. For over 70 years CarlisleIT has been providing leading-edge designs in wire and cable, connectors and assemblies for commercial and military aircraft, avionics, in-flight entertainment and communications systems.

This catalog was designed to provide a focused presentation of our product lines in regards to your market and products. While it is not a complete list of CarlisleIT's capabilities, it should provide a thorough starting point to aid you in your design considerations.

Thank you for considering CarlisleIT for your interconnect requirements and needs.

We Are Interconnect.



www.CarlisleIT.com



Table of Contents

RF/Microwave Connectors

Push-On	6
High Performance Threaded	10
Test Adapters	12
Swept Right Angle	14
Phase Adjusters	16

EMI Protection & Transient Voltage Suppression

Circular	18
Rectangular Filter	20
Transient Voltage Suppression	22

Backshells	24
-------------------------	----

Contacts	26
-----------------------	----

Crimp Splices	28
----------------------------	----

Terminal Grounding	32
---------------------------------	----

Specialty Interconnect Solutions

High Speed Ethernet	34
Specialty Connectors	36

Assemblies

Fiber Optics	38
RF/Microwave	40
Data Bus	42
High Density	44
Build-To-Print	46

RF/Microwave
Connectors

EMI Protection
& TVS

Backshells

Contacts

Crimp Splices

Terminal &
Grounding

Specialty Interconnect
Solutions

Assemblies

RF/Microwave Connectors

Push-On

Push-on Connectors were originally introduced to the market to facilitate dense packaging within RF/Microwave systems. Since then, they have become the interconnect system of choice for design in military, space and commercial applications. The push-on interconnect system relies on a floating female-to-female adapter—commonly referred to as a “bullet”—to enable stacking of boards equipped with male PCB connectors.

Applications

- » SATCOM
- » Radars and Antennas
- » Electronic Warfare
- » Missile Defense
- » C4ISR
- » High Reliability
- » General Purpose Test
- » Wireless Test
- » Semiconductor Test
- » Military Aerospace and UAV
- » Available in board-mount, field-replaceable, bullets, hermetic and cable connector configurations

Scale Comparison

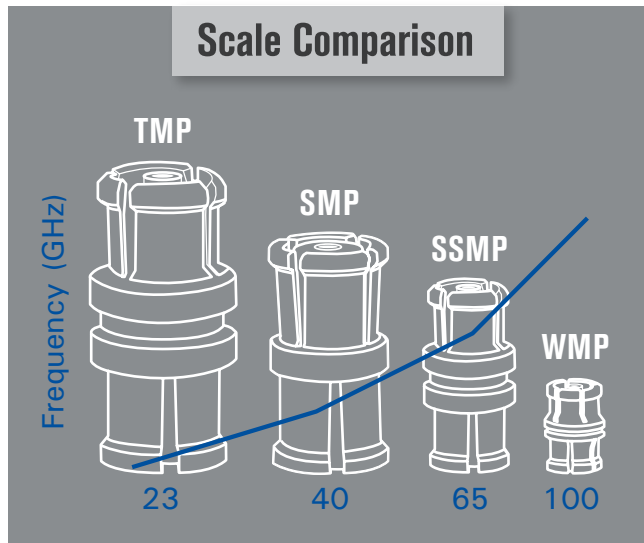

WMP® Connectors

The WMP® series is the smallest push-on product family and is designed to satisfy the demand for increased package density and reduced weight in microwave systems, while operating at frequencies up to 100 GHz.



SSMP® Connectors

The SSMP® interconnect interface is approximately 30% smaller than the standard SMP interface, and offers the flexibility of a blind-mate push-on connector system while maintaining a high standard for electrical performance up to 65 GHz.



SMP Connectors

The SMP push-on connector family, originally designed by CarlisleIT, is the ideal solution for board-to-board and cable-to-board connections within RF/Microwave systems operating up to 40 GHz.



SMP Assembly



Spring-Loaded SMP Bullets



PCB Board Mount



2-Port SMP Connector Block (Hermetic available)

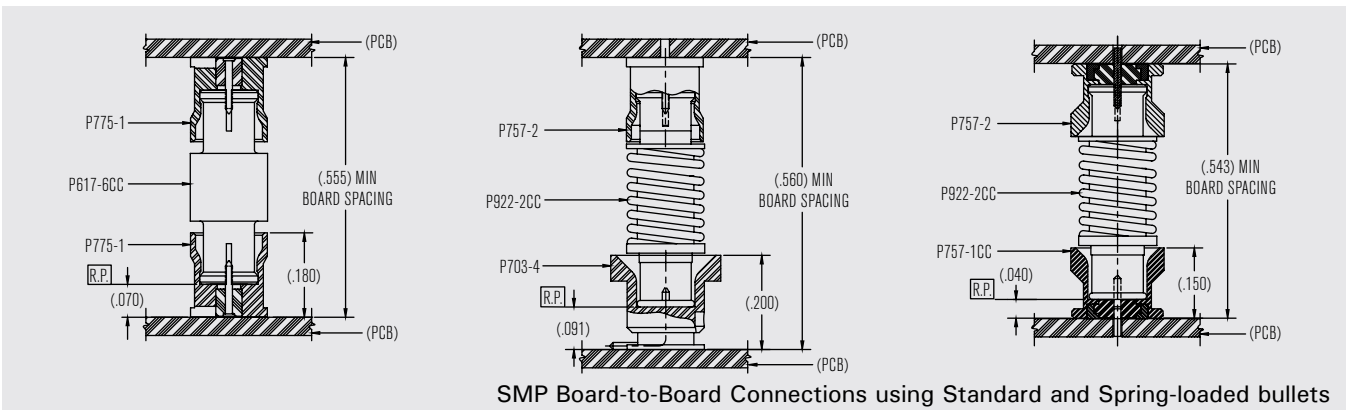

SMP Board-to-Board Connections using Standard and Spring-loaded bullets

RF/Microwave Connectors

SMP-L Secure-Lok™ Connectors

The SMP-L series is the latest addition to our push-on connector family. The SMP-L connector adds a patent pending locking mechanism to the standard SMP interface, referred to as Secure-Lok™. This makes the connectors ideal for rugged military and commercial applications up to 40 GHz, where susceptibility to vibration and other environmental factors have historically limited designers to use threaded connectors.



TMP® Connectors – High Power Push-On

The TMP® connectors are comparable in size to an SMA connector and are designed to provide a convenient blind-mateable solution specifically for high power applications. They are ideal for design in radar, missile and satellite systems, as well as commercial applications.



XMP™ Ultra High Power Connectors

The XMP™ high power interconnect series is designed to provide a convenient blind-mateable solution for ultra high power industrial applications, such as high powered lasers. The XMP™ series is durable in construction and can tolerate radial and axial misalignment for multiple engagement/disengagement cycles without degradation in electrical performance.



High Density Block Connectors

We also offer a variety of multi-position block connectors based on the standard interfaces – SMP, SSMP®, TMP® and WMP®. These are typically designed with 2, 4, 6 or 8 connectors integrated into a single block. Custom integrated designs are available upon request.



RF/Microwave Connectors

High Performance Threaded

CarlisleIT has over 30 years of experience in the design and manufacture of high performance RF/Microwave connectors. Our threaded coaxial connectors are widely designed into military, defense, space and commercial systems. They form the essential building blocks in many phased array radars, missiles, satellites and test instruments.

Applications

- » SATCOM
- » Radars and Antennas
- » Electronic Warfare
- » Missile Defense
- » C4ISR
- » High Reliability
- » General Purpose Test
- » Wireless Test
- » Semiconductor Test
- » Military Aerospace and UAV

SMA Connectors

The SMA series is our most extensive product line and includes a complete list of board mount, field replaceable, cable connector and adapter configurations. They are an ideal solution for microwave modules and systems up to 18 GHz.



EPsMA™ Connectors

The EPsMA (Enhanced Performance) series of connectors maintain the same physical dimensions of an SMA connector while extending the performance to 26.5 GHz. They are tuned to provide ultra-low VSWR over the frequency range, and are ideal for design into power amplifiers for mil/defense and commercial systems.



2.92mm (K*) Connectors

2.92mm (K) Connectors are precision microwave connectors with an air interface which provide mode free performance up to 40 GHz.



*K Connector is a trademark of Anritsu Company

Type N Connectors

The Type N series is used heavily in microwave systems, where higher power handling capability is needed. The series includes cable connectors and adapters and are available in both 12 GHz and 18 GHz designs.



TNC Connectors

TNC series is used in microwave systems up to 11 GHz. Our TNC connectors are ideal for space applications and are also available in High Reliability (Hi Rel) designs.



SSMA Connectors

The SSMA Connector is essentially a smaller version of the SMA connector. It was mainly designed for board-to-board connections and is commonly used with .085 semi-rigid cables. The SSMA connector provides mode-free performance to 36 GHz, and is also available as board mounts, field replaceables and other configurations.



BNC Connectors

The BNC Connector continues to be the predominant choice in low frequency RF and aerospace applications. We carry a variety of BNC cable connectors that provide superior performance up to 4 GHz.



RF/Microwave Connectors

Test Adapters

CarlisleIT has perfected our continuous transmission line right-angled design to produce optimally matched low loss adapters. Our threaded test adapters are designed for optimal performance and come standard in a passivated stainless steel body with a captivated Beryllium Copper center conductor to ensure mating repeatability.

Applications

- » SATCOM
- » Radars and Antennas
- » Electronic Warfare
- » Missile Defense
- » C4ISR
- » High Reliability
- » General Purpose Test
- » Wireless Test
- » Semiconductor Test
- » Military Aerospace and UAV

RF/Microwave Adapters

We offer a full gender family of straight and right angle adapters in different connector options, to cover applications ranging from DC–65 GHz. All of our adapters are 100% tested to ensure optimum performance over their respective frequency range. In order to facilitate adapting from one connector configuration to another, we also offer between-series adapters for different connection types. In this case, the frequency range is limited by the connector with the lower frequency of operation.



Precision Swept Right Angle Adapters



In-Series Adapters



Between-Series Adapters



Available Configurations

Threaded	Push-On
SMA	SMP
Type N	SSMP
TNC	WMP
K (2.92 mm)	TMP
2.4 mm	
V (1.85 mm)	

We also offer a variety of customized options for adapters, which include, but are not limited to, non-standard lengths, different connector options and additional testing.

RF/Microwave Connectors

Swept Right Angles

CarlisleIT introduced the Swept Right Angle adapters to market to improve upon the performance of a standard right angle adapter. Since then, the design has also been employed to other configurations such as panel mounts, field replaceables and cable connectors to fit the desired application needs. These are also available in almost all of the RF/Microwave connector families we offer.

Applications

- » SATCOM
- » Radars and Antennas
- » Electronic Warfare
- » Missile Defense
- » C4ISR
- » High Reliability
- » General Purpose Test
- » Wireless Test
- » Semiconductor Test
- » Military Aerospace and UAV

Low VSWR Swept Right Angle Connectors

The swept right angle connector utilizes a one piece center contact that is curved within a radius tube housing. The proprietary manufacturing process ensures a true coax geometry from end to end. The radius design configuration allows for a better performance at higher operating frequencies in a tighter package and greatly reduces shock or vibration failures. We offer many different interfaces with the swept profile, including: SMAs, SMKs (2.92mm), TNCs along with a variety of in-series and between-series adapters and custom configurations to fit your application needs.





VSWR Performance of the 5490 Swept Right Angle Adapters

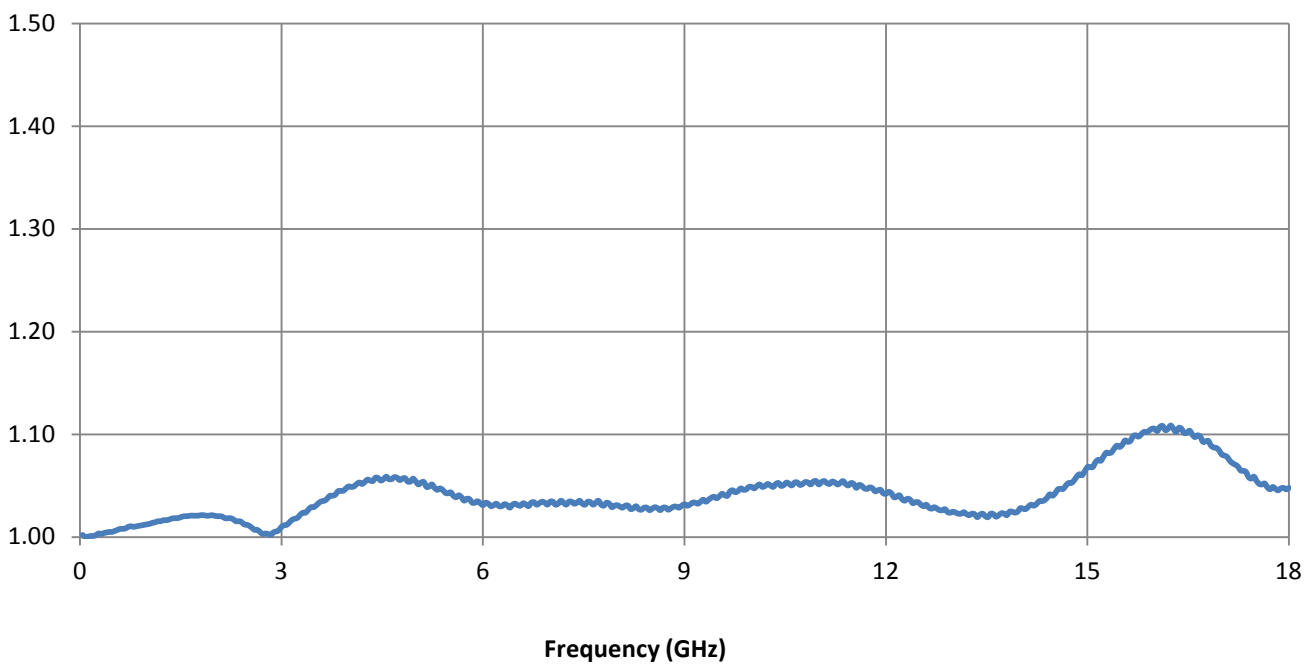

RF/Microwave Connectors

Phase Adjusters

Our Phase Adjuster connector family of products are ideal for high performance military communications (phased array antennas) and commercial applications. A precision mechanical movement provides continuously varying phase shifts, while maintaining 50 Ohm impedance over the entire frequency range.

Applications

- » SATCOM
- » Radars and Antennas
- » Electronic Warfare
- » Missile Defense
- » C4ISR
- » High Reliability
- » General Purpose Test
- » Wireless Test
- » Semiconductor Test
- » Military Aerospace and UAV

Block Style

Block Style Phase Adjusters provide up to 18 GHz, low insertion loss, smooth continuous phase adjustment and rugged compact housing. There is no external length change.



Adapter

The Phase Adjustable Adapters provide up to 50 GHz, low insertion loss and smooth continuous phase adjustment. They have positive resettable locking mechanism.



Cable Style

Cable Style Phase Adjusters provide up to 26 GHz smooth continuous phase adjustment and positive resettable locking mechanism. Cable configurations that are available include .141, .085 and .047 OD.





EMI Protection & Transient Voltage Suppression

Circular Filter

Our circular family of filter products include all the major military connector specifications along with special shell styles and arrangements. All of the standard filter circuits, PI, C, LC/CL and T plus a number of specialty circuits are included in our toolbox. Connectors are manufactured using state of the art processing, feature ferrite immobilization, mechanically sealed rear termination and are tested to meet Mil-Standard Qualification requirements (substituting filter electrical requirements for the standard electricals).

Applications

- » Avionics Boxes
- » Engine Controls
- » Military and Commercial Radios
- » Radars

38999 Series I

A bayonet coupling quick disconnect that can be configured in all mounting styles with a variety of finishes that is environmentally sealed and scoop-proof.



38999 Series II

A low profile, bayonet coupling, quick disconnect that can be configured in all mounting styles with a variety of finishes and is environmentally sealed.



38999 Series III

A "Triple Start Thread" quick disconnect that can be configured in all mounting styles with a variety of finishes, that is environmentally sealed, scoop-proof and can handle high shock and vibration requirements.



38999 Series IV

A "Breech-Lock" quarter turn quick disconnect that can be configured in all mounting styles with a variety of finishes, that is environmentally sealed, scoop-proof and can handle high shock and vibration requirements.



EMI Protection & Transient Voltage Suppression

Rectangular Filter

Our rectangular family of filter connectors cover Arinc 404 and 600 (with front removable/front release #22 socket contacts), both standard density and hi-density M24308 (D-Subs), M83513 (Micro-D), EPX, plus a number of special shell styles and arrangements, with ARINC sealing as a key advantage. All of the standard filter circuits, PI, C, LC/CL and T are available plus the flexibility to do the circuitry in either planar or chip on board technology.

Applications

- » Radars and Antennas
- » Electronic Warfare
- » C4ISR
- » High Reliability
- » Military Aerospace and UAV
- » Railroad/Mass Transit
- » Avionics

D-Sub and Micro-D

These D-Sub and Micro-D connectors are designed with machined shells for harsh environments and all the standard filtering circuits seen in the circular filter connectors. The D-Subs come in standard and hi-density arrangements up to 104 pins and the Micro-D's can be wired as required.



Micro-D



D-Sub



D-Sub Right Angle

ARINC 600

The ARINC 600 family of connectors offer higher contact counts, shell polarization, power and signal contacts and low mating forces. CarlisleIT's designs feature a modular approach using standard shells and inserts with a filtered backpack.

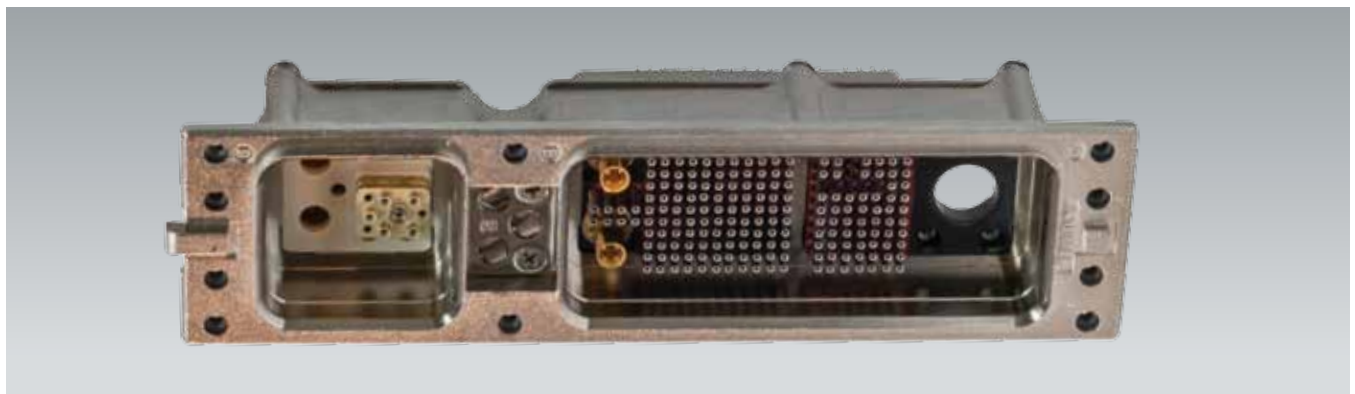

ARINC 404

ARINC 404 filter connectors include front release/front removable contacts and high pin counts that can include signal, power, RF, fiber and filter contacts.



EPX

This is a standard Radiall modular connector that has been modified to accept removable filter modules.



777 Rack

EMI Protection & Transient Voltage Suppression

Transient Voltage Suppression

Our family of Transient Voltage Suppression (TVS) connectors can be incorporated into any of our circular or rectangular product configurations and can include the filtering if required. Our unique packaging “diode in board” can handle power up to 3k watts while saving space and weight.

Applications

- » Radars and Antennas
- » Electronic Warfare
- » C4ISR
- » High Reliability
- » Military Aerospace and UAV
- » Avionics

TVS Connectors

CarlisleIT packages TVS protection into all of our connector product lines utilizing an embedded diode (embedded into a PCB) for space and weight savings as well as improved performance. This innovative design resembles (mechanically) a filter assembly so it can be packaged into the connector in the same proven manner and in tandem if necessary. TVS connectors are available with 600 to 2500w diodes to meet some of the highest levels of RTCA DO-160 protection, screened to J level standards and capable of meeting the environmental requirements of their specific Mil-spec's.

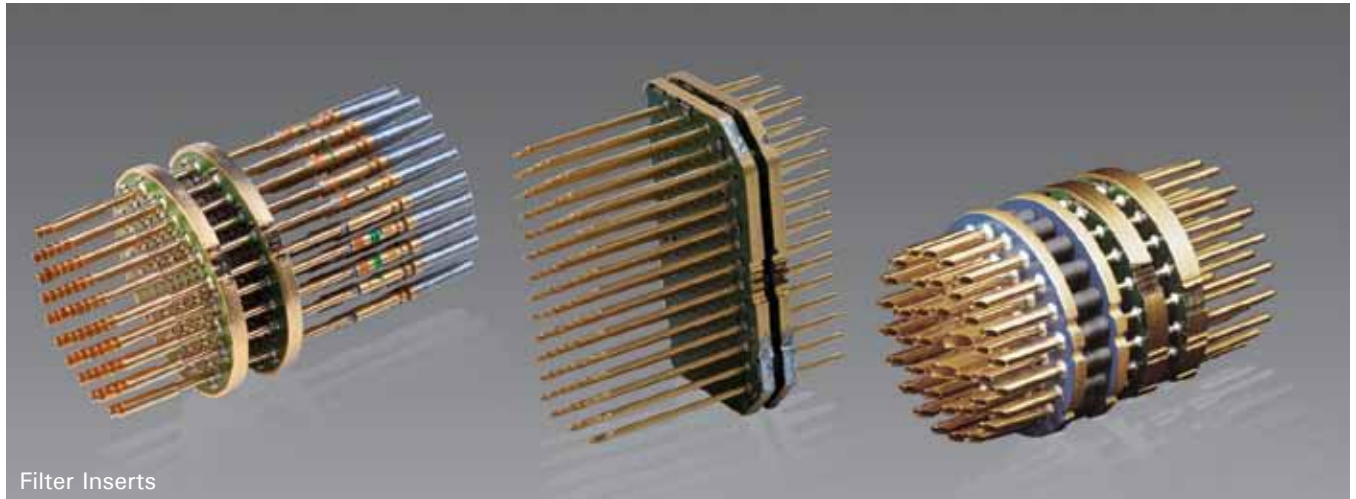

Filter Inserts

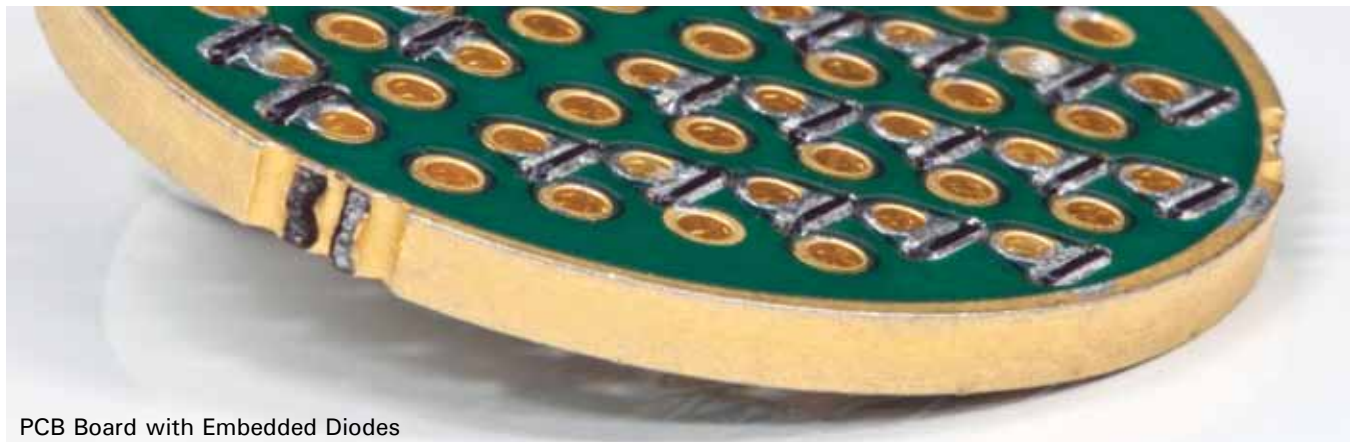

PCB Board with Embedded Diodes

Mechanical & Environmental Performance

Test Description	Procedure
Temperature Cycling	Method 1003, MIL-Std-1344, Condition A
Moisture Resistance	MIL-STD-202, Method 106
Durability	500 Matings at a rate of 200 ± 100 cycles per hour
Shock	Method 2004, MIL-STD-1344, Test Condition D
Vibration	Method 2005, MIL-STD-1344, Test Condition VI, Letter J, 8 Hours longitudinal and perpendicular axes
Fluid Immersion	MIL-STD-1344, Method 1016, Fluids (a) and (d)
Salt Spray	MIL-STD-202, Method 101, Condition B
Humidity	MIL-STD-1344, Method 1002, Condition B



Backshells

Overview

Our Backshells are ideal for EMI emission controlled applications such as In-Flight Entertainment systems and others that require lightweight and small form factors as well as a high degree of corrosion resistance and ROHS compliance. The majority of our Backshells have the ability to be mounted in both front and rear surfaces of system panels/boxes which allows flexibility in your system design. In addition, our Backshells have unique tie strap/screw hole side mount features that can provide additional stability in securing the cable assemblies to system structures.

Applications

- » Aircraft Structures
- » Broadband
- » In-Flight Entertainment
- » Cabin Management
- » Avionics
- » Military Aerospace and UAV

Lightweight Backshells

CarlisleIT's Lightweight Series Backshells are designed to minimize weight and maximize internal space and EMI shielding. The Lightweight (LW) Series Backshells are an ideal solution for high-end commercial and aviation cables where weight and/or EMI shielding are critical. Our LW series Backshells also have a number of unique features that improve the ease of assembly and overall system stability.



Compact D-Sub



EN4165

Flexible Backshells

The Flexible Backshells are designed to have an extremely tight bending radius in a 90° configuration, while providing a high degree of stability in terms of strain relief with minimal deformation of wire insulation.



Multi-Exit Backshells

Multi-Exit Angle Backshells have a unibody style that are configurable for both straight and 90° cable exits. Designed for ease of manufacturing and rework in the field, they accommodate many types of shield terminations and a wide range of cable diameters.

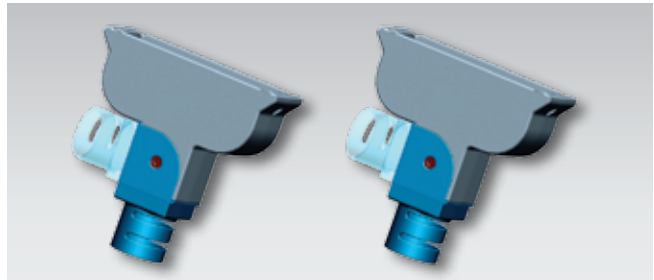

Straight Exit Angle Backshells

The Straight Exit Angle Backshells are extremely compact and lightweight, offering a straight cable exit. They have a body tapped style and high precision with a minimal air gap.

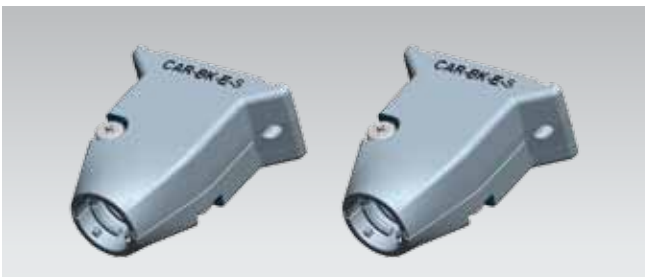

Universal Spring Latch

CarlisleIT's Universal Spring Latches provide high stability locking in panel and inline applications. The high strength stainless steel provides excellent corrosion and stress resistance.

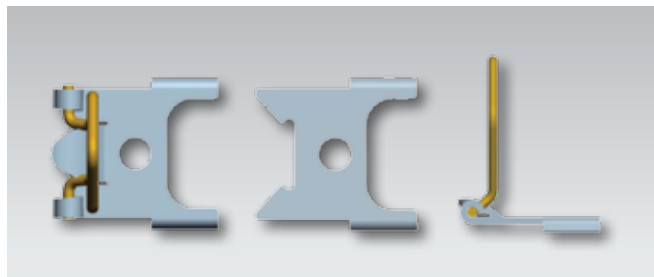

Contacts

Overview

CarlisleIT is the world's largest independent manufacturer of high reliability contacts. We maintain over 400 QPL approvals for AS39029 contacts, far more than any other manufacturer. In addition to Mil-Std contacts, we also offer the full line of EN3155, BACC and ESC contacts. Our single pieced machined contacts provide tensile strength and vibration resistance above and beyond other manufacturers.

Applications

- » SATCOM
- » Radars and Antennas
- » Electronic Warfare
- » Missile Defense
- » C4ISR
- » Instrumentations
- » Factory Automation
- » Alternative Energy
- » Oil and Gas Exploration
- » Heavy Equipment
- » Railroad/Mass Transit
- » Military Aerospace and UAV

PC Tail

We have designed and manufactured thousands of Printed Circuit Tail contacts for all of the major connector families. Whether you choose from one of our existing styles or we build to your exacting specifications, we are the #1 source for PC Tail contacts.



Coaxial, Twinax and Triax

Coaxial contacts for Mil-C-38999, ARINC and many other connector families are available. Our Coaxial contacts are used in critical communication systems, commercial & military satellites and telecom, as well as navigation and integrated avionics applications.



Solder Cup/Wire Wrap

We provide both. Whether you are prototyping or wiring up a test application, we can provide you with the Solder Cup or Wire Wrap contacts you need.



Crimp

A Mil-Spec Crimp contact. From standard Crimp contacts to reduced crimp barrels or custom designed for unique wire applications, we are the leading manufacturer of crimp contacts for the Mil-Aero industry.



Thermocouple

At 36,000 feet on a 70,000 lb thrust jet engine or miles down an oil exploration hole, our contacts can take the punishment. What may be exotic contacts to others have become one of our standard product offerings which brings decades of experience to your application.



Custom

Special materials, designs or configurations – we can handle them all. Involve us with your design engineering team early in the process so we can help you to develop the most economical contact for your particular application.



Crimp Splices

Overview

Our crimp splices are ideal for aerospace and defense applications, oil and gas exploration, heavy equipment and military ground vehicles where small form factor, ease of installation, flexibility and improved sealing characteristics is essential.

Applications

» Used wherever the need for an environment resistant wire-to-wire splice is required. Operational temperature range for Sealed Crimp Splices is -65 to 150°C and for Heatless Crimp Splices is 175°C.

Sealed Crimp Splices

CarlisleIT manufactures crimp barrels using a cold head machining process to provide superior mechanical strength before and after crimping. We use low durometer thermoplastic sealing rings which expand at the same rate creating a more durable sealing material. This is measurable via the 100% pass rating on the altitude emersion test and easily identifiable to the touch.

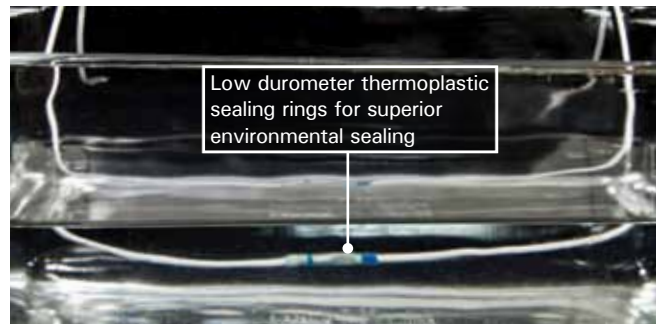
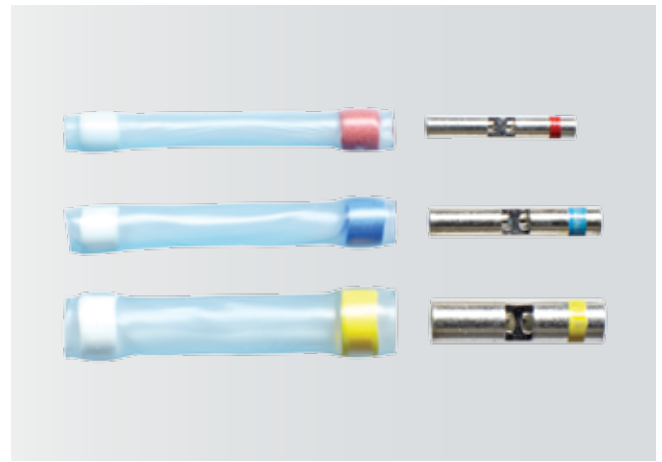
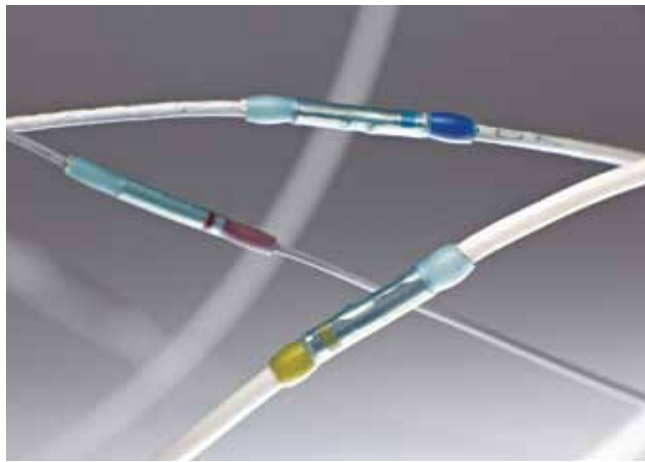

Specifications

Part No.	Military Designation	Wire Range	A Dia	B Dia	C	D	E	Finish	Color Code
H-C2005G	N/A	20-26 AWG	.050	.080	.510	.245	.085	Gold	Red
H-C2005S	N/A		.045	.075	.490	.225	Min	Silver	
H-C2005T	M81824/1-1							Tin	
H-C1605G	N/A	16-18 AWG	.069	.106	.585	.280	.110	Gold	Blue
H-C1605S	N/A		.064	.101	.565	.260	Min	Silver	
H-C1605T	M81824/1-2							Tin	
H-C1205G	N/A	12-14 AWG	.102	.153	.585	.280	.170	Gold	Yellow
H-C1205S	N/A		.097	.147	.565	.260	Min	Silver	
H-C1205T	M81824/1-3							Tin	

Crimp Splice

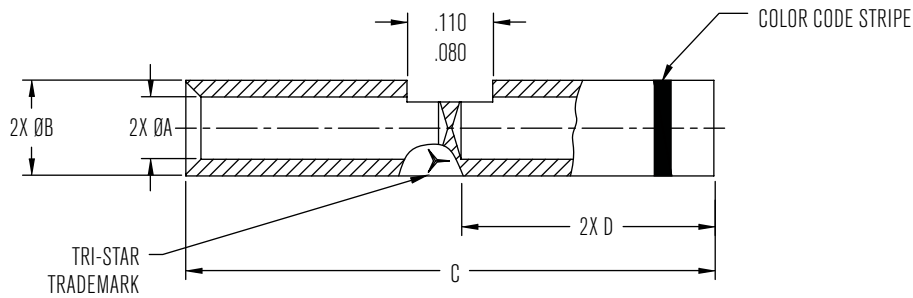

Insulation Sleeve

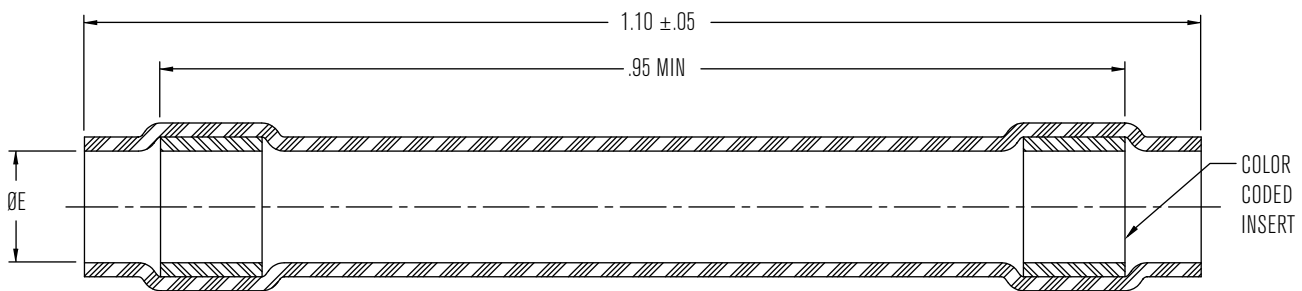

Crimp Splices

Heatless Crimp Splices

CarlisleIT's Heatless Crimp Splices are manufactured to give you high quality performance in the harshest operating environments, while reducing downtime with quick and easy installation using a positive locking insulator assembly. Since there is no heat required to install, the new Heatless Crimp Splice will save considerable labor hours as flammable fuels no longer need to be purged prior to repair.

The Heatless Crimp Splice is needed wherever maintenance is required on, or near, flammable liquids to achieve a superior seal. This product can be expanded beyond just military and commercial aircraft applications to oil & gas exploration and refineries, heavy equipment, industrial machinery, marine vessels and military ground vehicles.



Specifications

Military Designation	Part Number	AWG Range	ØA	ØB	C	D	E Max.	F Max.	ØG Max.	ØH Min.	Color Code
AS81824/14-1*	H-C2015N	20, 22, 24, 26	.050 (1.27) .045 (1.14)	.080 (2.03) .075 (1.91)	.510 (12.95) .490 (12.45)	.245 (6.22) .225 (5.71)	1.230 (31.24)	1.450 (36.83)	.22 (5.59)	.085 (2.16)	Red
AS81824/14-2*	H-C1615N	16, 18	.069 (1.75) .064 (1.63)	.106 (2.70) .101 (2.57)	.585 (14.86)	.280 (7.11)	1.400 (35.56)	1.622 (41.20)	.26 (6.60)	.116 (2.95)	Blue
AS81824/14-3*	H-C1215N	12, 14	.102 (2.59) .097 (2.46)	.153 (3.89) .147 (3.73)	.565 (14.35)	.260 (6.60)	1.535 (38.99)	1.750 (44.45)	.32 (8.13)	.164 (4.17)	Yellow

* AS81824 provided for reference only.

Crimp Splice

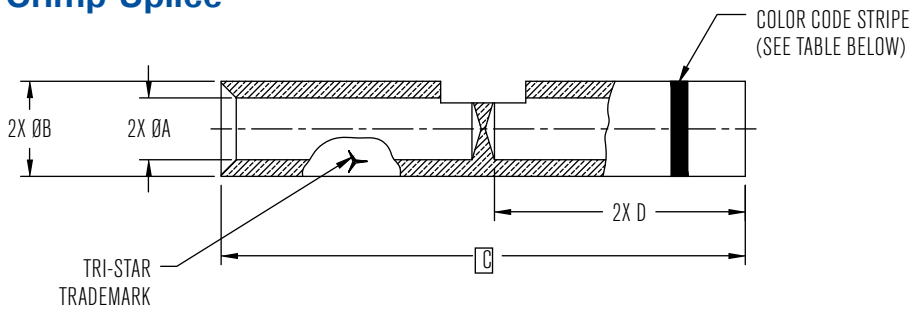

Insulation Sleeve

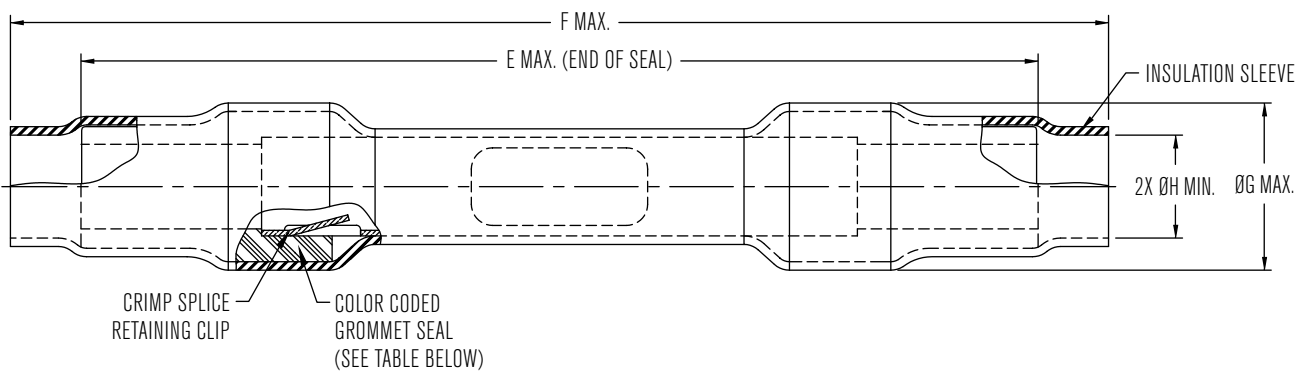

Terminal Grounding

Overview

The Terminal and Grounding Block family of products are designed for critical applications in the transportation and military industry. Our products have over two decades of flight experience where stringent FAA requirements are imposed. Whether one of our standard products will meet your needs or we build to your exacting performance specifications, you can count on our expertise to handle your power distribution needs.

Applications

- » Commercial Aircraft
- » Military Aerospace & UAV
- » Rail Mass Transit
- » Heavy Equipment

Grounding Block

Custom designs include jet engine fire wall applications, high temperature applications, high vibration applications and general purpose applications.





Specialty Interconnect Solutions

High Speed Ethernet

Our Octax™ connector family of products are ideal for high speed data transmission/receiving such as high definition video, communication and In-Flight Entertainment networks that require extremely light weight and compact sizes, harsh environmental endurance as well as high performance durability.

Applications

- » 1-10 Gb/s or Higher Ethernet Networks
- » In-Flight Entertainment
- » Infotainment
- » Data Loading
- » High Speed Sensor Networks
- » Battle Command Central Network Systems
- » High Speed Video Systems

Octax™ Gigabit Contact – Packaging Options



Key Characteristics

The High Speed Data Octax™ connectors are much smaller and lighter than the competitive products, yet possess outstanding performance in terms of crosstalk, return loss and insertion loss which ultimately provides superior data transmission speeds. In addition, our Octax™ connectors have been innovatively designed with multiple industry standard configurations, housings and platforms. This allows a high degree of flexibility of options to suit various system design applications. The High Speed Data Octax™ connectors are capable of delivering data transfer speed of 10 Gb/s or higher. The connectors have excellent corrosion resistance, shell to shell connectivity, EMI shielding and are optimized for 1G and 10G applications. These connectors have a unique contact retaining mechanism for ease of manufacturing and field rework. They are compact, lightweight, blind-mateable and scoop-proof. All Octax™ connectors are environmentally sealed and ROHS compliant.

The cable for the Octax™ system is available in six versions covering data rates from 1 Gb/s and 10 Gb/s. Cables are available in both 24AWG and 26AWG offerings. The CarlisleIT Octax™ solution cables provide superior performance while maintaining flexibility and minimal diameters.

Electrical Data

- » Dielectric Withstand Voltage: 1000 VDC
- » Current and Voltage Rating: 4 amps and 115 VAC
- » Shell to Shell Contact Resistance: < 3.0 milliohms
- » Insulation Resistance of Inserts: > 5.0x10⁹ ohms

Mechanical Data

- » Mating Cycles: > 500
- » Mating/Unmating Force: 2 lb/1 lb
- » Contact Retaining Force: > 8 lbs

Panel Mount Options



Single Panel Mount Plug



2 Gang

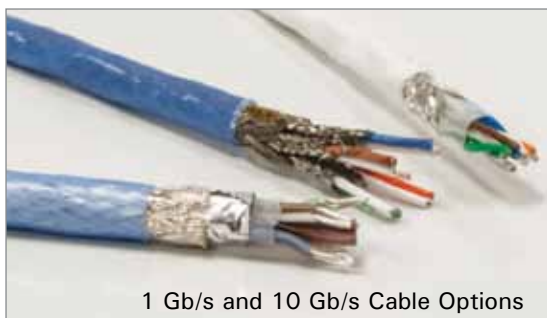

1 Gb/s and 10 Gb/s Cable Options



4 Gang

Specialty Interconnect Solutions

Specialty Connectors

Some of our more unique capabilities include the complete design and manufacturing of custom connectors whether it be Card Edge, Circular, D-Sub or Rectangular configurations. We understand the complexities involved with designing systems that have tight space constraints and need to operate in some extreme environments. From the design of new latching mechanisms, rubber and plastic components, to the machining and die casting of shells, we can do it all.

Applications

- » Commercial Aircraft
- » Military Aerospace & UAV
- » Rail Mass Transit
- » Heavy Equipment

CQ Connectors

The CQ connector's unique design emits an audible click when mated. It is ideal for blind-mating applications and hard-to-reach places, such as under passenger seats. It mates with any standard D-Subminiature or MIL-C-24308 connector, when lockpost hardware is installed.



CBC/Galley Connectors

Our CBC/Galley connectors are used by the airframe OEMs and the suppliers of galleys and galley insert modules. They have been standardized for ease of maintenance and interchangeability. They are designed to accommodate the many different plug-in warming devices and other ancillary units presently in use world-wide.



CB/CBX - Plastic Connectors

These lightweight style connectors have a positive latch type lock. CB/CBX connectors are perfect for PC board and blind-mating applications.



ARINC 400 & 600

Our ARINC connector capabilities range from standard to complex with custom inserts, filtering, and harnessing options available – we do it all.

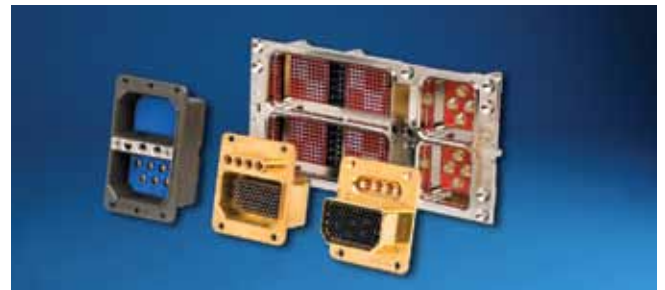

CLP/CLPP Circular Connectors

Ideal for blind-mating in In-Flight Entertainment systems and aircraft galley applications where intermateability with MIL-C-26500 is preferred. These connectors will readily mate with MIL-C-26500 bayonet type plug MS24266R series connectors and can be PC board mounted.



CSLT Connectors

The CSLT is a quick coupling connector which can be used with PC Tail and Solder Cup contacts in the receptacle and standard AS39029 size 20 contacts in the plug. Also, this connector can be polarized in six different positions. The bayonet post design on this quick coupling connector is just an example of the capabilities we have available for your custom interconnect solutions.



D-Subminiature Connectors

We have many D-Subminiature designs to choose from and with the full resources of CarlisleIT available we offer – beyond our custom designs – Filtered D-Subminiature Connectors out of our Tempe, AZ facility and Lightweight Backshells out of our Kent, WA.

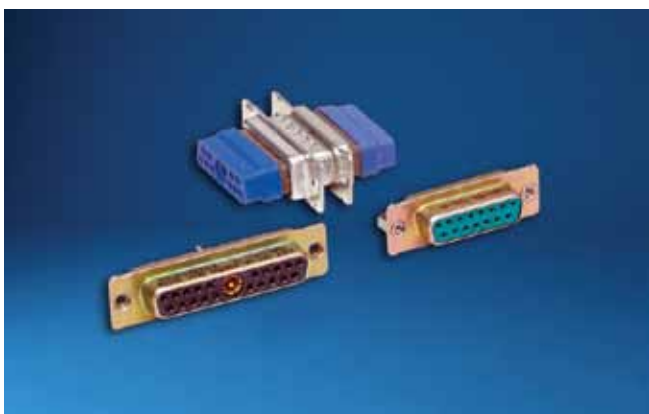

Micro-USB

CarlisleIT has packaged a Micro-USB plug and receptacle into a Mil-C-38999III size 11 shell to provide Mil-Spec performance for a commercial industry standard in a very small footprint. The connector can support computers, phones, internet and other devices for various types of data transfers and power in harsh environments where a small package is required. Additional filtering and transient voltage suppression can be added to the connectors upon request.



Assemblies

Fiber Optics

Our Fiber Optic assemblies are specifically designed to provide maximum performance and durability in the demanding conditions found in aerospace, military, industrial and other harsh environments.

Applications

- » In-Flight Entertainment
- » Electronic Warfare
- » Shipboard Assemblies
- » Industrial Application
- » Test Interface / Reference Quality Assemblies
- » Aerospace Grade Assemblies
- » Military/Tactical Assemblies

LITEflight® EP Assemblies

The LITEflight® EP series provides all the performance and benefits necessary to function in the harsh environments of your aerospace and military applications but with lower loss, tighter bend radii, improved thermal stability and better handling during termination and installation.



LITEflight® HD Assemblies

LITEflight® HD cables offer a multi-channel fiber cable in the smallest package, compatible with industry leading MPO connector interfaces and emerging multi-fiber termination connectors.



Fiber Optic Test Kits

CarlisleIT offers fully self-contained testing kits custom designed to the application with reference quality test adapter assemblies, Insertion Loss Test Kits, Visual Inspection Video Scopes, Optical Time-Domain Reflectometers (OTDRs), Optical Backscatter Reflectometers (OBRs) and other test devices.



Test and Measurement Equipment Kit



Adapter Cable Test Assembly

Assemblies

RF/Microwave

CarlisleIT's RF/Microwave assemblies are manufactured using cables and connectors that were engineered for maximum frequency response while maintaining both low attenuation and return loss. 100% of our high frequency assemblies are tested to ensure performance and reliability in a wide variety of applications.

Applications

- » SATCOM
- » Avionics
- » Radars and Antennas
- » Electronic Warfare
- » Missile Defense
- » C4ISR
- » High Reliability
- » General Purpose Test
- » Wireless Test
- » Semiconductor Test
- » Military Aerospace and UAV

AccuPhase® Assemblies

AccuPhase® is a complete product family of low loss and phase stable flexible coaxial cable with frequencies up to 40GHz. All cables are engineered to terminate with high performance RF connectors for optimum performance.



Semi-Rigid Assemblies

The semi-rigid cable assemblies are among the highest quality assemblies available today for use within RF/Microwave systems. All semi-rigid assemblies are custom-built to meet your specifications.



Semi-Flex® Assemblies

The Semi-Flex® coaxial cable assemblies are hand-formable cables that allow simple high quality connections for use within RF/Microwave systems, as well as, for making external connections to other equipment.



Avionics RF Assemblies

Lightweight and high-performance are the keys to reducing operational expenses. That is why CarlisleIT continues to design and manufacture both standard RF cables/cable assemblies and low PIM assemblies with design features that maximize system integrity and minimize cost of ownership.



Assemblies

Data Bus

The key features of our Data Bus Assemblies are that they are lightweight, cost-effective and a high-speed Ethernet interconnect solution capable of operating at data transmission speeds of 10Gb/s or higher. Ideal for use in radar and weather mapping systems, communications, navigation systems, In-Flight Entertainment equipment, EFB systems and all aircraft applications where temperature, shielding and flexibility are critical concerns.

Applications

- » In-Flight Entertainment
- » Cabin Management
- » Avionics

Octax™ Assemblies

CarlisleIT's Octax™ Assemblies house four Ethernet pairs in separate low profile cells within a small envelope housing. The cables are available in two performance options: 1 Gb/s and 10 Gb/s. The connectors are lightweight and are capable of being utilized in a panel mount application. These assemblies have optimum shielding to minimize interference issues. They are developed for minimal insertion loss and superior protection against Electromagnetic Interference (EMI).



HDMI, DVI & Coax Digital Video Assemblies

CarlisleIT manufactures HDMI and other data bus cables that will allow you to gain the maximum performance from your system even at longer distances. They are designed to provide robust flexible cable solutions that support high-performance digital video cable connections that are optimized to reduce overall weight and cost, withstand the harsh environmental conditions of in-flight and ground operations, comply with all applicable airworthiness requirements and deliver reliable high-speed and high-definition performance.



Assemblies

High Density

Our High Density family of products are ideal for a wide variety of demanding, high-speed applications. Whether in ATE, Servers, Backplanes, Telecom Switches and many more, the High Density cable is the lowest cost answer for your high-speed digital or analog signal transmissions.

Applications

- » Ship and Ground Based Radar
- » Radio Communications
- » Test and Measurement
- » ATE
- » UAV

HDSI® - High Density Shielded Interconnect Assemblies

The HDSI® products are rugged, flexible, low profile, lightweight, micro-miniature ribbonized coax or differential pair cable assemblies that are optimized with matched impedance cable and/or printed circuit boards. The manufacturing is performed with CarlisleIT's unique laser cable prep and termination process which allows for the processing of ultra fine pitch and gauge cable with the high yields and quality required in today's applications.

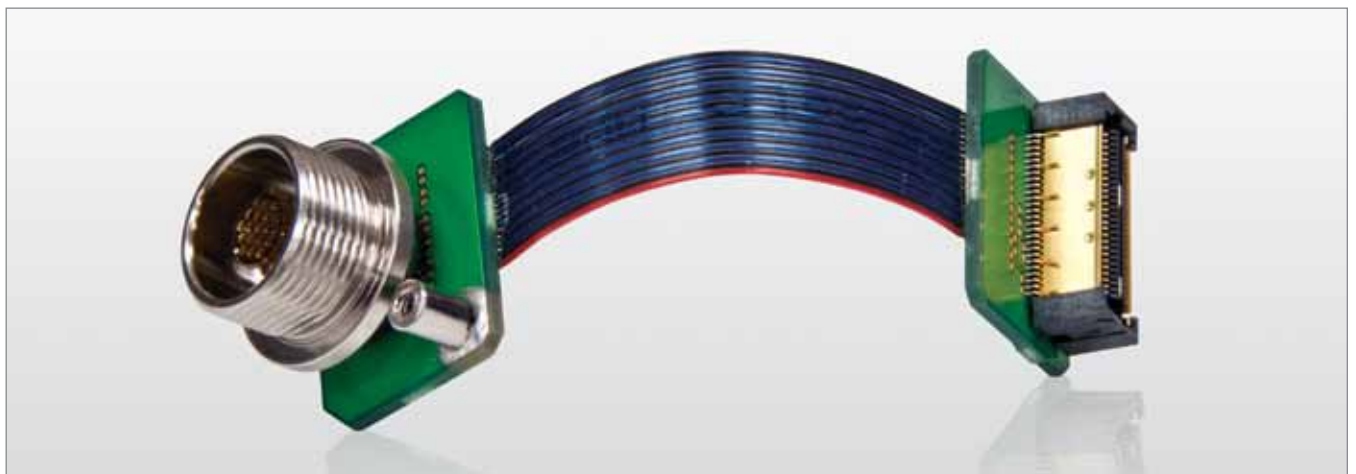
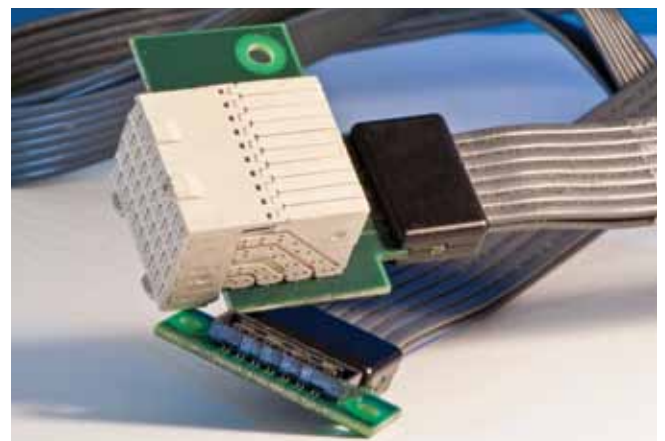

HDRFI® - High Density RF Interconnect Assemblies

HDRFI® is available as an assembly in three product line offerings: RF D-Sub, RF Circular and custom applications. The assemblies can be used with a 26AWG coax for internal applications or 24AWG for external requirements. Features include: high bandwidth, high density, sealed construction and small form factor.

- » The RF D-Sub connector family is available in four different shell sizes and can be used in cable-to-cable, cable-to-board or board-to-board applications. Designed with high performance in mind, the insert arrangements are maximized to hold impedance controlled size 16 type RF contacts.
- » The RF Circular connector family is designed for high performance applications where high vibration is a factor. The circular product line consists of shell sizes 15 – 25 and are based on the D38999 specification. RF Circular Mixed Signal connectors combine both power and high frequency RF contacts into the same connector body.
- » The ARINC custom inserts fit into any standard ARINC 600 Series Size 2 or 3 shell. The shell Modules A,B,D or F will accommodate up to 33 RF connectors, shell Modules C or F will accommodate up to 20 RF connectors and all coaxial connections will work from DC to 40 GHz.
- » The HDRFI® mezzanine system allows for two boards to be connected without the need for a connector on each board. This allows for variable stack height, mixed signal options, unique shapes and custom applications.



D-Sub

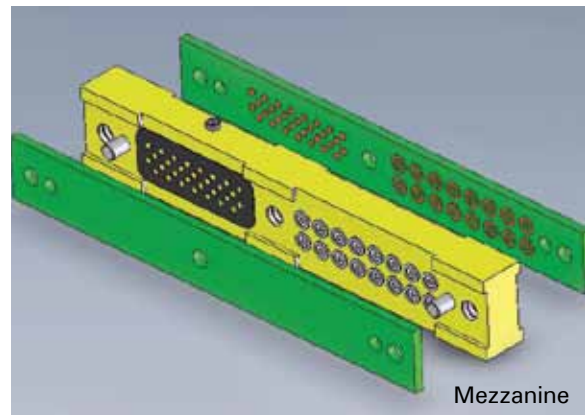

Mezzanine



ARINC



RF Circular

Assemblies

Build-To-Print

Build-To-Print at CarlisleIT is strategically aligned to give our customers complete control over the design and product modification process. Our Build-To-Print services provide our customers fully manufactured, tested and ready-to-install products built to your designs and specifications. Let us take the burden off your operations so you can focus on your core business. Operate leaner and more streamlined with CarlisleIT building your products on-time, with in-house quality checks and for less cost.

Applications

- » Specialized Wires and Cables for Aviation
- » Standard and Custom Connector Components
- » Wire Harness Assemblies
- » Coaxial Cable Assemblies
- » Custom Molded Cable Assemblies
- » ARINC Trays and LRU Enclosures
- » Fiber Optic Assemblies
- » Brackets, Components and Panels
- » Shelf and Rack Assemblies
- » Composite Structures and Monuments
- » Air Cooling Systems
- » Air Filtration Systems

Capabilities

With flexible solutions tailored to the customer, we have the technologies, expertise and infrastructure to carry out build-to-print projects with the efficiency and responsiveness that customers expect from CarlisleIT. Our full-service fabrication facilities are capable of manufacturing avionics support products from customer-supplied drawings with product modifications being made directly by the customer. CarlisleIT manufacturing engineers are involved as needed throughout the process to facilitate manufacturability, maximize cost-savings and minimize waste. Additionally, we incorporate a formalized program for tracking customer documents, revisions and updates to ensure customer-authorized change control and unit-to-unit repeatability between production runs.

Process

- » Manufacturing engineers and production personnel review customer-supplied drawings to ensure a cost-effective production
- » Recommended design or material modifications are submitted for customer approval prior to production
- » Approved customer-supplied drawings are entered into the Customer Document Log (CDL) with all updates recorded as needed during the production process
- » Final production adheres to strict in-house written procedures and approved engineering data to ensure the quality of the customer product



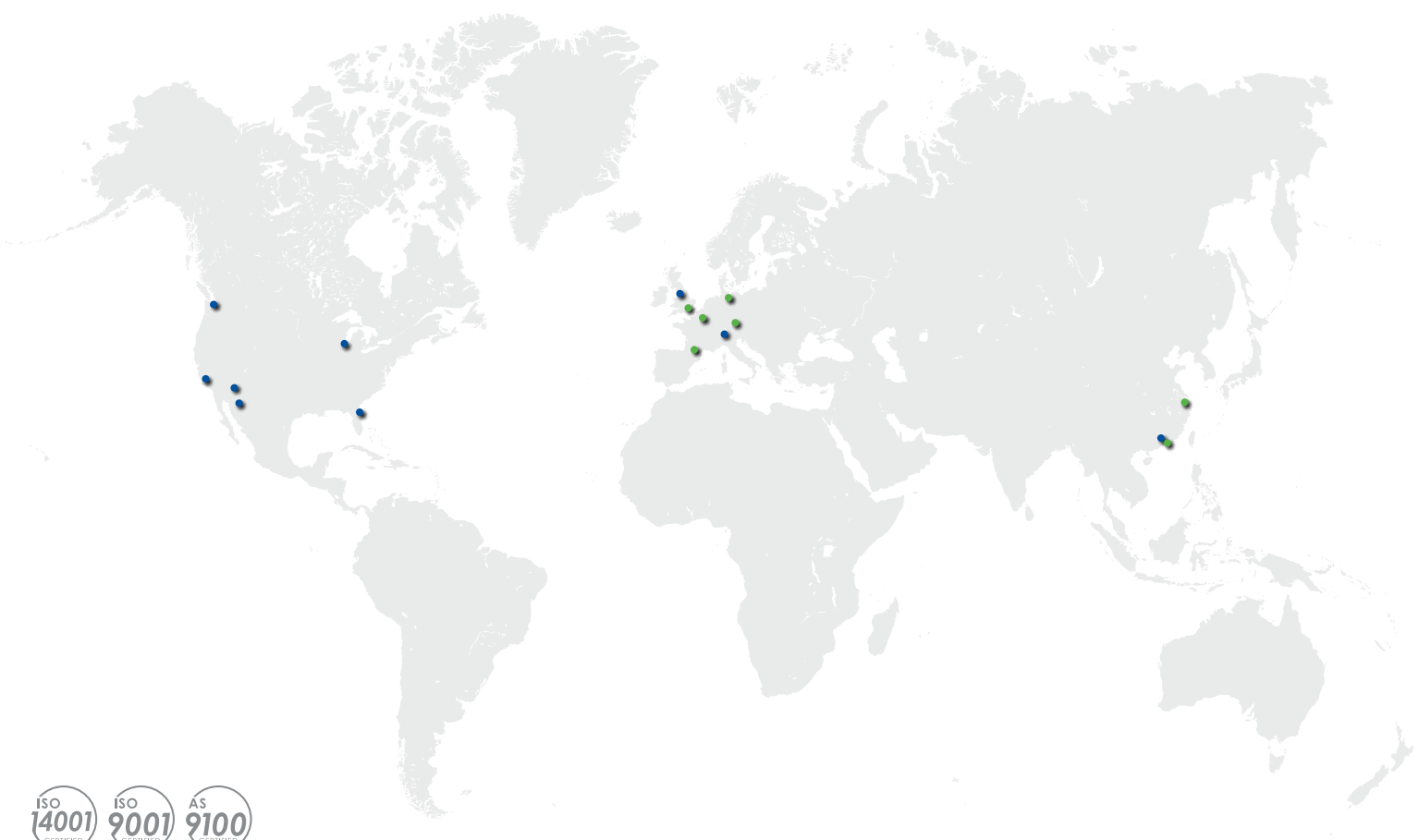

All of our facilities are
ISO9001 & AS9100 Registered

● Manufacturing & Sales | ● Sales

ST. AUGUSTINE, FL

Corporate Headquarters
Manufacturing & Sales
T 800.458.9960 / F 904.824.6706

EL SEGUNDO, CA

Manufacturing & Sales
T 310.536.0444 / F 310.536.9322

FRANKLIN, WI

Manufacturing & Sales
T 800.327.9473 / F 414.421.5301

LUGANO, SWITZERLAND

Manufacturing
T 41.91.611.51.61 / F 41.91.611.51.67

TEMPE, AZ

Manufacturing & Sales
T 480.730.5700 / F 480.730.5800

RIVERSIDE, CA

Manufacturing
T 951.788.0252 / F 951.788.6226

DONGGUAN, CHINA

Manufacturing & Sales
T +86.769.8102.6363 / F +86.769.8345.4972

LITTLEBOROUGH, UNITED KINGDOM

Manufacturing & Sales
T +44.1706.374015 / F +44.1706.370576

CERRITOS, CA

Manufacturing & Sales
T 866.282.4708 / F 562.494.0955

KENT, WA

Manufacturing & Sales
T 800.227.5953 / F 425.251.8826

NOGALES, MEXICO

Manufacturing & Sales
T 661.295.3100

